



Morrisville

Live connected. Live well.

Town of Morrisville

Public Works Department

Recommended Standards for Town Facilities

September 2023



Morrisville

Public Works

Public Works Recommended Standards for Amenities, Building Fixtures and Sustainability Initiatives

As the Town of Morrisville grows, the needs of our community increase along with the responsibility to maintain additional town facilities. In the last five years the facilities to be maintained have increased by approximately 40%. Given the small staff responsible for maintenance operations in Public Works, the efficiency of our processes must be improved to make better use of our labor force, increase longevity of fixtures and amenities, reduce maintenance cost, and increase sustainability of operations.

Fine tuning our processes requires minimizing time that is spent on activity other than support work. Continually bringing in new types of fixtures increases the complexity of maintenance operations and service time due to the required training with its operation, education to users, additional tools needed, lead time of spare parts and trial and error of support until field experience is acquired.

Standardization provides the following benefits:

- Minimizes costly operations
- Reduces start up time due to learning curve for additional installs (i.e., education, install, operation)
- Increases performance
- Provides bulk price discounts when purchasing supplies

The purpose of this document is to identify amenities, building fixtures and sustainability initiatives currently used throughout town facilities and set the direction for future Town projects. This standardization will help to improve the effectiveness of maintenance support.

Nothing contained in this document is intended to supersede any regulations, ordinances, or approval procedures. All projects must comply with the Towns UDO and development procedures. The Town does not charge building permit fees for town projects however, permits are still required. Contractors working for the Town should not charge a building permit fee (they may charge a fee for the administrative part of applying for the permit).

Table of Contents

1. [Park & Smart Shuttle Stop Amenities Standards](#)
 - a. [Trash Cans](#)
 - b. [Recycling Cans](#)
 - c. [Dog Stations](#)
 - d. [Benches](#)
 - e. [Picnic Tables](#)
 - f. [Landscaping](#)
2. [Town Center Amenities](#)
 - a. [Single Trash/Recycle Cans](#)
 - b. [Dual Trash Cans](#)
 - c. [Benches](#)
 - d. [Bicycle Racks](#)
3. [Building Fixtures Standards](#)
 - a. [Bathroom Fixtures](#)
 - b. [Interior Building Fixtures](#)
4. [Pedestrian Bridge Structure Standards](#)
 - a. [Bridge Deck & Rails](#)
 - b. [Bridge Substructure](#)
 - c. [Culverts and Tunnels](#)
 - d. [Plan Review](#)
 - e. [Post Construction Requirements](#)
 - f. [Checklist for Acceptance](#)
5. [Sustainability Requirements](#)
 - a. [Solar](#)
 - b. [Ionization](#)
 - c. [EV Charging Infrastructure](#)
 - d. [Building Automation Systems](#)
 - e. [Material Waste Diversion](#)
6. [Attachment A – Building Automation System Sequence of Operation](#)
7. [Attachment B – Building Automation System Specifications](#)
8. [Attachment C – The Value of Building Automation Systems](#)
9. [Attachment D – Planting Details](#)
10. [Attachment E – Town Center Amenity Details](#)

1. Park & Smart Shuttle Stop Amenities Standards

a. Trash cans

- i. Receptacles are 36-gallon, Blue Round Receptacles with Expanded Steel and a vertical diamond pattern.
[Brand: Pilot Rock | Model: CN-R/D-32]
- ii. Liners are Black Heavy Duty Rigid Plastic Liners.
[Brand: Pilot Rock | Model: CN/B-1827]
- iii. Lids are Blue Round Plastic Domes with Square Doors. (24 inches inside diameter)
[Brand: Pilot Rock | Model: CN-SDR-24]

b. Recycling cans

- i. Receptacles are 36-gallon, Green Round Receptacles with Expanded Steel and a vertical diamond pattern.
[Brand: Pilot Rock | Model: CN-R/D-32]
- ii. Liners are Black Heavy Duty Rigid Plastic Liners.
[Brand: Pilot Rock | Model: CN/B-1827]
- iii. Lids Green Plastic Canopy for Recycling are 24-inch inside Diameter with 4.5-inch diameter recycling hole (website says 4-3/8 inches, quotes say 4.5 inches) and "Cans & Bottles Only" Recycling Lid Decal.
[Brand: Pilot Rock | Model: CN/N-3031PC5]

c. Dog stations

- i. Receptacles are 10-gallon, Green Steel Dog Waste System Receptacles with side-opening tops (perpendicular opening in relation to dog station pole).
[Brand: Uline | Model: H-3491]
- ii. Bag housing units are Matte Green Roll Bag Dispensers.
[Brand: Dog Waste Depot | SKU: DEPOT-003-GRN]
- iii. Liners are 60-gallon NAPCO Black Heavy Duty Municipal Liner -38 x 58,1.85N-XXSH (cans are too small for traditional liners, so trash bags line the cans instead).
[Brand: Image Supply Inc. | Item #: L58XXXH]
- iv. Dog station Bags The Purple Poop Bags, 200 bags per roll. Perforated tear-off – Universal Fit, Strong, Thick.
[Brand: Dog Waste Depot | SKU: DEPOT-111]

- d. Benches
 - i. Benches are Blue Channel Park Benches - Using 2x10 Perforated Steel with Embedded Post installation, Hot Dip Galvanized Steel frame finish, and are 6 feet H-Type.
[Brand: Pilot Rock | Model: SCXB/G-6]
- e. Picnic tables
 - i. Picnic Tables are Blue Everest Series 6-Ft Heavy Duty Picnic Tables.
[Brand: Everest Series | Item # 398-6005]
 - ii. ADA Picnic Tables are Blue Everest Series 8-Ft Heavy Duty ADA Picnic Tables.
[Brand: Everest Series | Item # 398-6007]
- f. Landscaping
 - i. Plant bed mulch – Designer Brown
 - ii. Playground mulch – Certified Playground Wood Fiber Mulch
 - iii. Grass – Tiffuf Bermuda (in most instances)
 - iv. Plantings – 70% native plantings goal if possible. See Attachment D for Planting Details

2. Town Center Amenities (See Attachment E for Details)

- a. Single Trash/Recycle Cans
 - i. Receptacles are 32-gallon, Powder coated bronze color, constructed of 3/16" x 1-1/2" and 1/4" x 2" flat bar, as well as 5/8" solid rod, Optional door included.
[Brand: Thomas Steele | Model: CRTRD-32-P]
 - ii. Liners are Black Heavy Duty Rigid Plastic Liners.
[Brand: Thomas Steele | Model: LIN-32]
 - iii. Lids are Powder coated bronze color, Elevated Dome Lids.
[Brand: Thomas Steele | Model: LIDD-ED-P]
- b. Dual Trash Cans
 - i. Receptacles are 32-gallon, Powder coated bronze color, constructed of 3/16" x 1-1/2" and 1/4" x 2" flat bar, as well as 5/8" solid rod, Optional door included.
[Brand: Thomas Steele | Model: CRTR2D-32-P]
 - ii. Liners are Black Heavy Duty Rigid Plastic Liners.
[Brand: Thomas Steele | Model: LIN-32]
 - iii. Lids are Powder coated bronze color, Elevated Dome Lids.
[Brand: Thomas Steele | Model: LIDD-ED-P]

c. Benches

- i. Benches Powder coated bronze color, Bench Frame: End (and center) frames are constructed of 1/2" x 2 1/2" (12.7mm x 63.5mm) carbon steel flat bar. Seating Materials: Vertical straps are 1/4" x 1-1/2" (6.4mm x 38.1mm) carbon steel flat bar, Horizontal straps are 3/16" x 1-1/2" (4.8mm x 38.1mm) carbon steel flat bar. Include optional Logo.
[Brand: Thomas Steele | Model: CRB-6-HS-P]

d. Bicycle Racks

- i. Bicycle Rack Powder coated bronze color, U bike racks are 35" high and constructed with 1.90" OD steel tubing and are 24" wide, With Custom Leaning Bar
[Brand: Thomas Steele | Model: U24-MORRISONVIL LE]

3. Building Fixtures Standards

a. Bathroom Fixtures: Inside each town bathroom, both park and administration buildings, there are six fixtures/devices currently utilized and accepted as a standard which are listed below:

- i. Toilet tissue dispenser: UniFirst provides a dual-roll dispenser to the town for no charge that utilizes the 7.5" rolls of toilet tissue. It is a Tork model T2 which mounts quickly, is very durable, easy to reload and secured with a lock mechanism.
- ii. Soap dispenser: UniFirst provides a foam soap dispenser that utilizes 1.25-liter bags of replacement soap. It is a GoJo model 5161 and comes without charge. They are easy to install, very durable, easy to reload and secured with a hidden cover release.
- iii. Towel dispenser (Administration Buildings only): Utilized in town administration buildings is the UniFirst touch-free towel dispenser by Tork, model 55-11-202. It is a battery-driven dispenser that is triggered by the wave of a hand and is purchased for a minimal cost. They mount quickly, are very durable, easy to reload and secured with a lock mechanism.
- iv. Hand dryer: Paper towel dispensers have been phased out in existing park bathrooms. Due to vandalism caused by flushing paper towels down the toilet that causes a backup, electric hand dryers are now being installed in park bathrooms. No specific model is being identified because the unit requires no supplies or servicing. The only requirement we have is that it is EnergyStar rated.
- v. Water faucet: All bathroom faucets in administration and park bathrooms are fixed temperature, touch-free faucets by Elkay, model LKB737C. They are primarily battery operated. In new construction, we require a 120v/20a duplex receptacle which drives a power pack, thus removing the need to routinely replace batteries.
- vi. Auto-flush toilet device: For all urinals and tankless flush-valve toilets, the Sloan Zurn Side Mount Automatic Flusher model 3325500 EBV-500-A is used. Battery operated and easy to install, they eliminate the manual flushing for these fixtures.

- b. Interior Building Fixtures: Inside each administration building, there are several fixtures utilized by town employees and the public.
 - i. Water fountain: The water fountains used is a bilevel, wall-mounted, touchless fountain that provides a bottle fill along with bubblers. The model used is the Elkay EZH2O Bottle Filling Station with Bi-Level model EZOOTL8WSSK. (Note: In a couple buildings where space is limited, the single-level Elkay EZH2O Bottle Filling Station model EMABF8WSSK is utilized)
 - ii. Kitchen faucet: The faucet used in the kitchens is the Moen Arbor 7594ESRS variable temperature pulldown kitchen faucet.
 - iii. Hand sanitizer dispenser: The dispenser used for hand sanitizer liquid throughout buildings is the Hillyard touch-free dispenser, model HIL 22283. It is provided by Image Supply and the unit is reliable, easy to reload the liquid refills and comes with batteries.

4. Pedestrian Bridge Structure Standards

The main consideration for structure type selection by Town Projects as well as developers is most likely the initial cost. Future maintenance costs will be covered through the Town's Bridge Maintenance Program. Selecting an appropriate superstructure type that meets both parties' objectives as well as the geometric and capacity needs of the crossing can be challenging. The following was developed as a guide in structure selection, design review, construction inspection, and acceptance for maintenance by the Town. The preapproved structure types listed below will not require a preliminary submittal to approve these bridge types (there will be a required submittal of the design itself).

- a. Bridges - Deck and Rails: Concrete, composite, or plastic deck material types are preferred by the Town and will be preapproved. All decking must have a minimum coefficient of static friction of 0.6, in both wet and dry conditions. Timber decking, if approved by the Town, shall be a minimum size of 3x8 nominal and must be sealed 2-4 months after installation. Sealant material must be submitted and approved by the Town or their authorized representative prior to application. The top board or handrail of all bridge rails must be composite or plastic material. Timber rail boards and pickets must be 2x6 or greater in size. Curbs must have blocking, or spacers present so that debris is not allowed to build-up between the deck and curb. All timber rail and curb components must be sealed 2-4 months after installation. Sealant material must be submitted and approved by the Town or their authorized representative prior to application.
- b. Bridges – Superstructures: The following bridge types will be preapproved by the Town: Precast concrete bridge types such as PermaTrak or equivalent. Painted steel superstructures will not be taken over and maintained by the Town. Pedestrian steel bridges shall be weathering steel or galvanized structural steel (weathering or galvanized) with a minimum of 5-inch concrete deck. Prefabricated truss spans such as Continental Bridges are also acceptable using weathering steel or galvanized steel. Deck should be concrete or composite plastic materials. Timber stringer superstructure types, if approved by the Town, must be properly sealed 2-4 months after completion. Sealant material must be submitted and approved by the Town or their authorized representative prior to application. Timber joists/stringers in direct contact with the ground or within 1ft clearance of ground level will not be taken over and maintained by the Town.

- c. Bridges – Substructures: Substructures with exposed timber or timber elements in direct contact with the ground will not be taken over and maintained by the Town. All end bents or abutments shall be a minimum distance of 5ft from the natural streambank. Any slope 2:1 (horizontal to vertical) or steeper must have rip rap or other scour and erosion control measures present.
- d. Culverts and Tunnels: Cast-in-Place or precast reinforced concrete culverts are recommended. Bottomless concrete culverts and concrete Con/Span type structures shall be reviewed for approval through the Engineering Dept. Aluminum culverts could be explored and corrugated metal pipe structures are not accepted and will not be maintained by the Town.
- e. Plan Review Submittal (Recommendation): The following is a list of engineering documents that should be required for review and approval as part of the commercial/residential plan review process with bridge/culvert structures.
 - i. Bridge plans, details, and specifications.
 - ii. Load and Resistance Factor Design (LRFD) design calculations and load ratings based on a minimum H5 loading.
- f. Post Construction Requirements (Recommendation)
 - i. Inspection by the Town or Town's authorized representative
 - ii. Developer issues Town 12-month warranty
 - iii. Town authorization to open bridge
 - iv. Initial inspection by Town representative within 10 months of bridge opening—36-month inspection cycle thereafter
 - v. Developer must address any deficiencies identified during inspection
- g. Bridge/Culvert Checklist for Required Documentation for Structure Acceptance and Turnover to Bridge Maintenance Program
 - i. Preapproved structure or documentation of discussion and approval from the Town
 - ii. Bridge plans, details, and specifications
 - iii. Design calculations and load ratings based on H5 loading
 - iv. 12-month developer warranty

5. Sustainability Requirements:

a. Solar

- i. PURPOSE: Off-set maximum electricity usage based on Duke Energy's monthly peak demand. Direct pay as part of the Infrastructure Reduction Act, as well as any other federal or state incentives should be accounted for in the net cost.
- ii. A stamped structural engineering assessment of all potential rooftop solar projects on existing facilities is required as part of the engineering design of the solar system. This shall be completed and provided prior to the design of the solar system commencing.
- iii. Certifications / Warranties
 1. Modules: 12-year warranty minimum but extended options should be disclosed based on manufacturer, 30-year warranty for power output.
 2. Inverter: SolarEdge 20-year extended warranty (preference), 12-year minimum warranty. API is required.
 3. Rapid Shut Down: 25-year extended warranty preferred, 7-year minimum.
 4. Labor/workmanship: 5 years.
- iv. Connectivity (any project, including BAS or solar)
 1. The Town will provide a wired hand-off for any equipment requiring connectivity. The project developer is then responsible from the hand-off to the connected equipment. The hand-off location should be in the nearest IT closet.
- v. Ratings
 1. Protection Rating: NEMA 3R.
 2. Safety: UL1741
 3. Grid Connection Standards: IEEE 1547, Rule 21, Rule 14 (HI).
 4. Emissions: FCC part15 class B
- vi. Fire Code Requirements must be met according to the most current NC Fire Code (section: 605.11-605.11.1.3.3).

b. Ionization

- i. PURPOSE: This process is intended to increase indoor air quality. Ionization helps remove harmful airborne particles such as bacteria, dust and viruses, which proactively attack and destroy airborne contaminants.
- ii. See spec sheet for a product (GPS-DM48-AC) the Town installed at Town Hall, which purifies the air using bipolar ionization. Note, staff is not indicating that the product must be the same, but it should provide the same function.

c. EV Charging Infrastructure

- i. PURPOSE:
The intent is for the Town to include EV-Ready or EVSE installed at a minimum as referenced in the UDO Section 5.10.3F.

ii. EV-Ready parking spaces are those that are deemed EV-Capable and also include a 240-volt outlet accessible to the parking space.

- A pair of 1 1/4" conduits
- A double pole breaker location in the service panel from which the above conduit is run.



EV Capable: Install electrical panel capacity with a dedicated branch circuit and a continuous raceway from the panel to the future EV parking spot.



EV Ready: Install electrical panel capacity and raceway with conduit to terminate in a junction box or 240-volt charging outlet (typical clothing dryer outlet).



EVSE Installed: Install a minimum number of Level 2 EV charging stations.

iii. If a Level 2 charger is to be installed, then see below:

- Certification / Warranties: 5-year warranty, 5-year portal access.
- Protection rating: NEMA 4 outdoor standards
- Preferred manufacturer / model: ChargePoint CT4025-GW1 (Dual output, gateway option, bollard unit - 208/240V, @30A with cord management, 23' cords, 8' CMK
- CPCLD-Commercial-5 - 5yr prepaid commercial cloud plan
- CPSupport-Active – Initial station activation of cloud services CT4000-Assure5 - 5 yr prepaid assure plan
- CPSupport-Sitevalid <https://chargepoint.ent.box.com/v/CT4000-BR-EN-US>

iv. Consult with Public Works/Sustainability to assess the need for a Level 3 DC Fast Charger for all Town CIP construction and/or renovation projects.

- Dedicated 480V 100amp circuits are needed for each fast charger to be installed.

v. Additional EVSE Guidance

- Always allow for additional power capacity to provide for increasing the number of chargers at a particular site in the future.
- The proposed placement and installation of EVSE infrastructure or equipment shall not allow for any violation of the American with Disabilities Act of 1990.
- No EV charging stations shall be placed in flood prone areas.

vi. EV chargers should be fed from an independent Duke Energy meter.

d. Building Automation Systems

- i. PURPOSE: Create 'Smart' buildings for operational optimization particularly for monitoring purposes. This is only needed for major facilities: Public Works, Town Hall, Fire Stations 1, 2 and 3, Morrisville Aquatics & Fitness Center, Public Safety (PSMS). See Attachment A- Sequence of Operations and Attachment B - Niagara Specs sheets for additional details. Refer to Attachment C for an analysis completed by staff titled "The Value of Building Automation Systems (BAS) in Town Buildings".

- ii. Data / IoT Requirements
 1. For IT connectivity, an API (application programming interface) is required, allowing the ToM to easily share data on the Open Data Portal.
 2. For any equipment requiring connectivity, such as a JACE, it should be hard-wired for hand-off at nearest IT network closet. Thermostats can be wireless.
- e. Material Waste Diversion
 - i. Landfill diversion goal of 65% for all new Town CIP construction and/or renovation projects.
- f. Native Plant Materials
 - i. Town of Morrisville projects have a goal of providing a minimum of 70% native plant material (including trees) for required landscaping. The Town may utilize the following recommended plant list or provide a NC native plant as categorized by the NC State Extension Office. Additional trees may be selected from the NC Forest Service's Urban Tree list.
 - NC State University Extension: <https://plants.ces.ncsu.edu>
 - North Carolina Native Plant Society: <https://ncwildflower.org/recommended-native-species>
 - Invasives List adopted from City of Raleigh: <https://cityofraleighdrupal.blob.core.usgovcloudapi.net/drupal-prod/COR24/invasive-species-native-alternatives.pdf>
 - NC Urban Tree List: [NCFS Urban Tree List](#)

Attachment A

Building Automation Systems

1 GENERAL SEQUENCE OF OPERATION REQUIREMENTS

- 1.1. The following requirements are applicable to all sequences of operation for this project:
- A. Sequences specified herein indicate the functional intent of the systems operation and may not fully detail every aspect of the programming that may be required to obtain the indicated operation. Contractor shall provide all programming necessary to obtain the sequences/system operation indicated. This includes but is not limited to delays, interlocks, limiters, etc.
 - B. Contractor shall provide testing documentation of all sequences prior to project completion. Refer to specifications for requirements.
 - C. Alarms – All points being controlled to a setpoint shall alarm when out of range. Provide both a high and low alarm threshold setpoint for each point. Alarm all safeties. Alarm all status vs command mismatches. Unless noted otherwise.
 1. All alarms shall be sent to a front-end alarm console. Coordinate with owner on alarm classes and priorities. Coordinate with owner on staff receiving alarm via email, phone, etc.

- D. Trending – Trend all points and alarms. Digital inputs and outputs shall be trended on change of value (COV). Analog inputs and outputs shall be trended on 15-minute intervals. Setpoints shall be trended on COV. Unless noted otherwise.
- E. Provide users with full or limited access for read, write and schedule permissions based on the owners' request. Contractor shall coordinate owner requirements before final commissioning of system.
- F. Controls shall be BACnet.
- G. All BAS systems shall use direct, 4-20 mA signals for analog inputs to humidity, pressure and other devices (where possible), where a signal less than 4 mA will generate a fail state. Resistive inputs (temperature, etc) shall have a low limit and high limit resistivity setpoint for fail state. Analog outputs shall use direct, 4-20 mA signals for analog outputs to VFDs (speed command), dampers, valves and other devices (where possible), where a signal less than 4 mA will generate a fail state.

1.2. Scheduling

- A. Occupied Period: Generally, systems will be fully operational throughout this period and ventilation air shall be continuously introduced. Space temperature setpoints will generally be in the "normal" range of 69°-77°F.
- B. Unoccupied Period: Period of time when the building or zone is not in use and unoccupied. Ventilation air shall not be introduced.
- C. Preoccupancy Period: Time prior to the Occupied Period when the systems are returning the space temperatures from setback to "normal" or occupied setpoints (warm-up and cool-down). Time period shall be determined by an optimum start strategy unless otherwise specified.
- D. Setup occupied period for 24/7/365; to be adjusted by user later. Provide capability to limit user's access to schedule changes.

1.3. Graphical Interface

- A. All graphic screens shall indicate date, time, and outside air temperature, relative humidity and dew point (via Niagara weather service).
- B. Provide a graphical display for each system, with a schematic of the unit and the following points:
 1. All points called for on the schematic and/or in the sequence.
 2. Additional points requested by owner/engineer.
- C. Group setpoints into a single location on graphic. Provide icon beside setpoints to indicate point is changeable. Provide icon beside overridable points to indicate point is over-ridable. All outputs shall be overridable (if user has sufficient privileges) from main graphic screen unless otherwise noted.

2 DUAL FUEL, VARIABLE SPEED AIR HANDLING UNITS (W/ FACTORY-THERMOSTAT)

2.1. General

- A. Dual fuel, variable speed air handling units require factory-supplied thermostats to vary compressor and fan speeds to maintain temperature and humidity at full and part load conditions. Currently, there is no straight-forward way to integrate the thermostats into the Town's Tridium system. The factory-supplied thermostat does have an internet-accessible (but non-integrable) thermostat for control. However, it does not provide the full, desired functionality the Town wishes. As such, a monitoring system will be provided by the controls contractor in parallel with the factory-supplied thermostat for the additional functionality required, which is detailed in the sequence below. In the long-term, the AHU vendors should provide an eventual integration path to the Tridium system. At that time, the thermostats could be upgraded/replaced (if desired) and integrated.

B. Factory-Thermostat

1. The factory-thermostat will be provided by the AHU vendor. Prior to construction, the AHU vendor will coordinate with the Town's IT Department on how to connect the thermostats to the Town's dedicated BAS network. Login information will be created for users as identified by the Town. Any desired functionality by the Town shall be programmed by the AHU vendor, where capable by the factory thermostat.
 - a. The dedicated BAS network (BLN, reference specifications) may still be under construction at check-out of equipment. As such, contractor(s) shall return upon completion of BAS network to connect factory-thermostats.
2. Factory-thermostat shall be sufficient and robust enough to allow system to operate independently from the BAS. Factory controls shall be configured/programmed to achieve the sequence as written below.
3. Factory-thermostat will allow for user setpoint adjustment. The thermostat shall allow maximum and minimum limits to be set for the user setpoint.
4. Factory-thermostat will allow for user occupancy override. Occupancy override shall place system into occupied mode for two hours (adj).
5. Factory-thermostat shall include a display.
6. Provide humidity sensing and dehumidification control (via fan speed reduction).

2.2. Operation

A. Safety Devices: Safeties shall be in operation at all times.

1. Smoke Detector: When the smoke detector is active, stop fan, and return dampers to off positions. Safety shall be hardwired and require manual reset (reset through smoke detector).
2. Float Switch: When the float switch is active, stop fan, and return dampers to off positions. Safety shall be hardwired. Float switch shall be installed on the auxiliary drain connection for the AHU.

B. Fan

1. The fan shall cycle with heating and cooling, without circulation.

C. DX Coil and Emergency Heat

1. Stage/modulate compressor(s) to provide DX cooling to maintain the space at the cooling setpoint (72°F, adj). If the space temperature drops below the heating setpoint (68°F, adj), the AHU shall energize/de-energize the reversing valve, and stage/modulate compressor(s) to provide DX heating to maintain the space at the heating setpoint. Disable DX heating when outside temperature is below 20°F, adj.
2. If the DX heating cannot maintain the space temperature at the heating setpoint, stage/modulate emergency heat to maintain the space at the heating setpoint.
3. Provide a minimum 2°F (non-adj) deadband between cooling and heating setpoints.

D. Dehumidification

1. Fan and compressor speeds will be slowed to keep relative humidity in the space below 65%. Reheat will not be used for dehumidification control (not possible with heat pump configuration).

E. Outside Air Damper

1. Open the outside air damper (where applicable) when the fan is commanded to run. Outside air damper shall be shut when fan is off.

2.3. Unoccupied Mode

- A. AHU shall be off. Increase cooling setpoint to 78°F (unoccupied cooling setpoint, adj) and decrease heating setpoint to 62°F (unoccupied heating setpoint, adj).
- B. If the occupancy override is pressed, or the space temperature rises above the unoccupied cooling setpoint, or falls below the unoccupied heating setpoint, place the AHU into preoccupancy mode. The AHU shall control to the occupied setpoints.
- C. The AHU shall return to unoccupied operation when occupied setpoints are reached, the minimum runtime of 30 minutes (adj) has been met, and the occupancy override expires.

2.4. Pre-Occupancy Mode

- A. AHU shall operate as described above.
- B. Unit shall enter preoccupancy period prior to occupied setpoint in accordance with optimum start/stop strategy to prevent the need to start emergency heat and heat space with DX only.

2.5. Additional Monitoring (by Controls Contractor)

A. Safety Devices

1. Monitor safety circuit (smoke detector plus float switch) for each AHU. Provide DPDT relay at each AHU for each safety. The first pole of relay will be used for AHU shutdown. The second pole of relay will be used for DI monitoring to BAS. Provide and mount relays such that a tripped safety is easily identified by the pilot light going out.

B. Fan

1. Determine fan status through a current sensor designed for EC motors.
2. If the fan does not run for 24 hours, generate an alarm.

C. Supply Temperature

1. Monitor AHU supply temperature.
2. If the outside air temperature is above 60°F, the supply fan is running, and the supply air temperature does not reach 55°F (adj) after 5 minutes, generate alarm.

D. Filters

1. Generate an alarm for filter change when fan runtime exceeds user input maximum.

E. Bi-Polar Ionization

1. Monitor alarm contacts on bi-polar ionization units. Monitor IDU-1 thru 6 (IDU-7 separate monitoring) with a single input. Generate a bi-polar ionization alarm when any unit fails.

2.6. Graphical Interface

- A. Provide a graphical display for the Air Handling Unit, with a schematic of the unit and the following points:
 1. Safety circuit status
 2. Supply fan status and alarm
 3. Filter runtime and time to next change
 4. Supply air temperature and alarm
 5. Bi-Polar Ionization alarm

The controls contractor shall provide a hyperlink on the graphics which points to the login location for the factory-supplied thermostats. The hyperlink will open the factory-thermostat login screen in a separate browser tab, where the monitoring system and factory-thermostat system can be compared by switching between browser tabs.

3 - MINI-SPLIT AIR HANDLING UNITS

3.1. Operation

A. General

1. Thermostat will allow for user setpoint adjustment. The BAS shall allow maximum and minimum limits to be set for the user setpoint.
2. Thermostat will allow for user occupancy override. Occupancy override shall place system into occupied mode for two hours (adj).
3. Thermostat shall include a display.
4. Provide humidity sensing.

B. Safety Devices: Safeties shall be in operation at all times.

1. Float Switch: When the float switch is active, stop fan. Safety shall be hardwired. Float switch shall be installed by manufacturer on cooling drain pan. Fan command/status mismatch is proxy for safety alarm.
2. When garage doors are open, stop fan. Safety shall be hardwired. Fan command/status mismatch is proxy for safety alarm.

C. Fan

1. The fan shall either:
 - a. run continuously, or
 - b. cycle with heating and cooling, without circulation, or
 - c. cycle with heating and cooling, plus circulation. If fan does not run for 30 minutes (adj) due to heating or cooling, enable fan to run for 5 minutes (adj). Timer shall be reset after every circulation, heating or cooling cycle, regardless of fan elapsed runtime.

Provide dropdown on front-end for user selection. Initial configuration will be cycle without circulation.

D. DX Coil and Emergency Heat

1. The AHU will control the DX cooling. Stage/modulate compressor(s) to provide DX cooling to maintain the space at the cooling setpoint (72°F, adj). If the space temperature drops below the heating setpoint (68°F, adj), the AHU shall energize/de-energize the reversing valve, and stage/modulate compressor(s) to provide DX heating to maintain the space at the heating setpoint. Disable DX heating when outside temperature is below 20°F, adj.
2. If the DX heating cannot maintain the space temperature at the heating setpoint, stage/modulate emergency heat to maintain the space at the heating setpoint.
3. The BAS shall provide a minimum 2°F (non-adj) deadband between cooling and heating setpoints.

E. Dehumidification

1. If the relative humidity in the space rises above 65% (adj), generate alarm.

F. Filters

1. Generate an alarm for filter change when fan runtime exceeds user input maximum.

3.2. Unoccupied Mode

- A. AHU shall be off. Increase cooling setpoint to 78°F (unoccupied cooling setpoint, adj) and decrease heating setpoint to 62°F (unoccupied heating setpoint, adj).
- B. If the occupancy override is pressed, or the space temperature rises above the unoccupied cooling setpoint, or falls below the unoccupied heating setpoint, place the AHU into pre-occupancy mode. The AHU shall control to the occupied setpoints.
- C. The AHU shall return to unoccupied operation when occupied setpoints are reached, the minimum runtime of 30 minutes (adj) has been met, and the occupancy override expires.

3.3. Pre-Occupancy Mode

- A. AHU shall operate as described above.
- B. Unit shall enter pre-occupancy period prior to occupied setpoint in accordance with optimum start/stop strategy to prevent the need to start electric heat strip and heat space with DX only.

3.4. Graphical Interface

- A. Provide a graphical display for the Air Handling Unit, with a schematic of the unit and the following points:
 - 1. System on/off and occupancy mode
 - 2. Supply fan on/off, mode, and runtime
 - 3. DX stages, reversing valve, and heating/cooling mode
 - 4. Emergency heat stages
 - 5. Filter runtime and time to next change
 - 6. Room temperature and heating/cooling setpoints
 - 7. Room temperature setpoint max and min limits
 - 8. Room override status
 - 9. Room humidity, alarm and alarm setpoint (where applicable)

4 - CONSTANT VOLUME AIR HANDLING UNITS (CV AHU)

4.1. Operation

A. General

- 1. Wall module (used for space temperature control, at location of existing thermostat) will allow for user setpoint adjustment. The BAS shall allow maximum and minimum limits to be set for the user setpoint.
- 2. Wall module will allow for user occupancy override. Occupancy override shall place system into occupied mode for two hours (adj).
- 3. Wall module shall include a display.
- 4. Provide humidity sensing at locations specified (see equipment schedule). Provide combination temp/humidity sensor/wall module where sensors are at same location.
- 5. AHU serves multiple spaces with different usages. Provide future capability for one additional wall module or space temperature sensor to be added to the controller. In the future, via the graphic, user shall be able to:
 - a. Adjust to what temperature the AHU controls to. User selection of the control method will include controlling to a specific wall module temperature, an average of all temperatures, the highest temperature, or the lowest temperature.
 - b. Adjust to what temperature setpoint the AHU operates at. If each wall module has

setpoint adjust, each wall module may be configured up/down from the “master setpoint,” and as such the AHU will need to know what temperature setpoint to control to. User selection of the control method will include controlling to a specific wall module temperature setpoint, an average of all temperature setpoints, the highest temperature setpoint, or the lowest temperature setpoint. User shall be able to ignore wall module temperature setpoints from specific wall modules, such that they are excluded from the control possibilities listed above.

B. Safety Devices: Safeties shall be in operation at all times.

1. Fire Alarm Shutdown (where existing): When the fire alarm is active, stop fan, and return dampers to off positions. Safety shall be hardwired and require manual reset (reset through fire alarm system). Point is not required to be on DDC system. Fan status will be proxy for fire alarm.

C. Fan

1. The fan shall either
 - a. run continuously, or
 - b. cycle with heating and cooling, without circulation, or
 - c. cycle with heating and cooling, plus circulation. If fan does not run for 30 minutes (adj) due to heating or cooling, enable fan to run for 5 minutes (adj). Timer shall be reset after every circulation, heating or cooling cycle, regardless of fan elapsed runtime.

Provide dropdown on front-end for user selection. Initial configuration will be cycle without circulation.

2. Determine fan status through a current sensor designed for EC motors. If a fan fails to start as commanded, generate an alarm.
3. On a signal to start, after all safeties have been cleared, energize the fan.
4. If the fan fails, generate an alarm.

D. DX Coil and Emergency Heat

1. The AHU will control the DX cooling. Stage/modulate compressor(s) to provide DX cooling to maintain the space at the cooling setpoint (72°F, adj). If the space temperature drops below the heating setpoint (68°F, adj), the AHU shall energize/de-energize the reversing valve, and stage/modulate compressor(s) to provide DX heating to maintain the space at the heating setpoint. Disable DX heating when outside temperature is below 20°F, adj.
2. If the DX heating cannot maintain the space temperature at the heating setpoint, stage/modulate emergency heat to maintain the space at the heating setpoint.
3. The BAS shall provide a minimum 2°F (non-adj) deadband between cooling and heating setpoints.
4. Monitor supply air temperature.
 - a. If the DX heating is running, and the supply air temperature does not reach 80°F (adj) after 5 minutes, generate alarm.
 - b. If the DX cooling is running, and the supply air temperature does not reach 55°F (adj) after 5 minutes, generate alarm.

E. Dehumidification

1. If the relative humidity in the space rises above 65% (adj), generate alarm.

F. Filters

1. Generate an alarm for filter change when fan runtime exceeds user input maximum.

4.2. Unoccupied Mode

- A. AHU shall be off. Increase cooling setpoint to 78°F (unoccupied cooling setpoint, adj) and decrease heating setpoint to 62°F (unoccupied heating setpoint, adj).

- B. If the occupancy override is pressed, or the space temperature rises above the unoccupied cooling setpoint, or falls below the unoccupied heating setpoint, place the AHU into preoccupancy mode. The AHU shall control to the occupied setpoints.
- C. The AHU shall return to unoccupied operation when occupied setpoints are reached, the minimum runtime of 30 minutes (adj) has been met, and the occupancy override expires.

4.3. Pre-Occupancy Mode

- A. AHU shall operate as described above.
- B. Unit shall enter preoccupancy period prior to occupied setpoint in accordance with optimum start/stop strategy to prevent the need to start electric heat strip and heat space with DX only.

4.4. Graphical Interface

- A. Provide a graphical display for the Air Handling Unit, with a schematic of the unit and the following points:
 - 1. System on/off
 - 2. Supply fan status, on/off/alarm, mode, and runtime
 - 3. DX stages, reversing valve, and heating/cooling mode
 - 4. Emergency heat stages
 - 5. Filter runtime and time to next change
 - 6. Supply air temperature
 - 7. Room temperature and heating/cooling setpoints
 - 8. Room temperature setpoint max and min limits
 - 9. Room override status
 - 10. Room humidity, alarm and alarm setpoint (where applicable)
 - 11. Multi-zone AHU temperature and temperature setpoint control method, active and ignored wall modules

5 - INFRARED RADIANT HEATERS

5.1. Operation

A. General

- 1. Thermostat will allow for user setpoint adjustment. The BAS shall allow maximum and minimum limits to be set for the user setpoint.
- 2. Thermostat will allow for user occupancy override. Occupancy override shall place system into occupied mode for two hours (adj).
- 3. Thermostat shall include a display.

B. Safety Devices: Safeties shall be in operation at all times.

- 1. When bay doors are open, heaters shall continue to operate for 2 hours (adj). When time expires, stop heaters. Safety shall be hardwired to thermostat, and software programmed.
- 2. Freeze Protection: if the space temperature drops below 35°F (adj), energize space heaters to provide heating to maintain the space at the heating setpoint and generate an alarm. Space heaters will energize even if bay doors are open.

C. Heaters

- 1. If the space temperature drops below the heating setpoint (55°F, adj), the heaters shall energize to provide heating to maintain the space at the heating setpoint.

5.2. Unoccupied Mode

- A. Decrease heating setpoint to 50°F (unoccupied heating setpoint, adj).

Commented [CL1]: The only place we do use radiant heat is in fire station bays and when the door opens, we need to shut off the heat.

- B. If the occupancy override is pressed, or the space temperature falls below the unoccupied heating setpoint, place the heater into occupied mode. The heater shall control to the occupied setpoints.
- C. The heater shall return to unoccupied operation when occupied setpoints are reached, the minimum runtime of 10 minutes (adj) has been met, and the occupancy override expires.

5.3. Graphical Interface

- A. Provide a graphical display for the Infrared Radiant Heaters, with a schematic of the unit and the following points:
 1. System on/off and occupancy mode
 2. Heating on/off
 3. Room temperature and heating setpoints
 4. Room temperature setpoint max and min limits
 5. Room override status

6 - 24X7 GENERAL EXHAUST FANS, CONSTANT VOLUME, BAS MONITORED

6.1. Operation

- A. Fans shall be hardwired to run 24/7. BAS shall not start/stop exhaust fan.
- B. Determine fan status through a current sensor. If an exhaust fan fails, generate an alarm.

6.2. Graphical Interface

- A. Provide a graphical display for the Exhaust Fan, with a schematic of the unit and the following points:
 1. Exhaust fan status and alarm

Commented [CL2]: Running fans 24/7 means that the fire station bays will be pulling air in from the outside at times when CO levels are non-threatening. There should be CO sensors that turn the fans on and off.

7- GENERAL EXHAUST FANS, CONSTANT VOLUME, BAS CONTROLLED

7.1. Operation

- A. Start/Stop
 1. For exhaust fans interlocked with AHU operation: start/stop exhaust fan with associated air handling unit. See schedule for exhaust fans and their associated air handling unit.
 2. For exhaust fans that run continuously: start exhaust fan and run continuously, regardless of occupancy or air handler status.
 3. For exhaust fans controlled by temperature: provide a temperature sensor at location on floorplans. On a rise in space temperature, start the exhaust fan. On a fall in space temperature, stop the exhaust fan. Provide a minimum run time appropriate for the exhaust fan horsepower to prevent short cycling.
- B. Determine fan status through a current sensor. If an exhaust fan fails to start as commanded or stops running when commanded, generate an alarm.
- C. For exhaust fans with motorized backdraft dampers: provide logic, either hardwired or software, to ensure damper is open prior to starting the exhaust fan. If damper does not open, generate an alarm.
- D. For exhaust fans with VFDs: VFD is for balancing only. Provide hardwired start/stop command and status to VFD. Determine fan status through a current sensor designed for variable speed drives. Hardcode speed (as determined by TAB, non-adj) into VFD. Provide BAS network to VFD for points as described below or in schematic.
- E. Where a temperature-controlled exhaust fan serves a space with a heating source (unit heater, etc), use the same temperature sensor for both pieces of equipment, and provide deadband for setpoints to prevent simultaneous heating and cooling.

7.2. Graphical Interface

A. Provide a graphical display for the Exhaust Fan, with a schematic of the unit and the following points:

1. System on/off
2. Exhaust fan status, on/off/alarm, speed command, speed feedback, fault and fault text
3. Space temperature

8 - GENERAL EXHAUST FANS, CONSTANT VOLUME, LINE VOLTAGE THERMOSTAT

- 8.1. Reference drawings for exhaust fans controlled by line voltage thermostat. Exhaust fans shall operate independently from the BAS. Low voltage (24VAC) thermostats are not allowed.
- 8.2. Provide a line voltage thermostat at location on floorplans. On a rise in space temperature, start the exhaust fan. On a fall in space temperature, stop the exhaust fan.
- 8.3. For exhaust fans with motorized backdraft dampers: provide hardwired logic to ensure damper is open prior to starting the exhaust fan.
- 8.4. Where an exhaust fan serves a space with a heating source (unit heater, etc), use a dual - setpoint line voltage thermostat or two separate thermostats mounted at the same location. Clearly label heating and cooling thermostat to prevent confusion. Where possible, set thermostat setpoint end stops to prevent possibility of simultaneous heating and cooling. Note: not applicable for factory or unit-mounted thermostats

9 UNIT HEATERS, BAS CONTROLLED (ELECTRIC, HW OR STEAM)

9.1. Operation

- A. Provide a temperature sensor at location on floorplans. On a fall in space temperature, start the unit heater. On a rise in space temperature, stop the unit heater. Provide a minimum run time appropriate for the unit heater size to prevent short cycling.
- B. Unit heater fan shall cycle with the unit; fan shall not run continuously.
- C. Where unit heater serves a space with a cooling source (exhaust fan, etc), use the same temperature sensor for both pieces of equipment, and provide deadband for setpoints to prevent simultaneous heating and cooling.

9.2. Graphical Interface

- A. Provide a graphical display for the Unit Heater, with a schematic of the unit and the following points:
 1. System on/off
 2. Space temperature

10 UNIT HEATERS, LINE VOLTAGE THERMOSTAT (ELECTRIC, HW OR STEAM)

* Where unit heaters have factory- mounted thermostats, do not provide this sequence

- 10.1. Reference drawings for unit heaters controlled by line voltage thermostat. Unit heaters shall operate independently from the BAS. Low voltage (24VAC) thermostats are not allowed.
- 10.2. Provide a line voltage thermostat at location on floorplans. On a fall in space temperature, start the unit heater. On a rise in space temperature, stop the unit heater.
- 10.3. Unit heater fan shall cycle with the unit; fan shall not run continuously.
- 10.4. For HW and steam unit heaters: provide line-size two position valve. Valve shall cycle open/closed with the unit. Use the same output to cycle the fan and open/close the valve.
- 10.5. Where a unit heater serves a space with a cooling source (exhaust fan, etc), use a dual - setpoint line voltage thermostat or two separate thermostats mounted at the same location. Clearly label heating and cooling thermostat to prevent confusion. Where possible, set thermostat setpoint end stops to prevent possibility of simultaneous heating and cooling. Note: not applicable for factory or unit-mounted thermostats.

11 -VEHICLE EXHAUST SYSTEM (PLYMOVENT/SAFEAIR)

- 11.1. Provide monitoring of vehicle exhaust system (VES).
- 11.2. VES vendor shall provide two, dry contacts for BAS monitoring. VES vendor shall program contacts to alarm based on exhaust fan failures, high carbon monoxide, high nitrous oxide, as per Customer request. Generate alarm on contact closure.

12 -MISCELLANEOUS MONITORING AND CONTROL

12.1. Generator

- A. Monitor generator run and generator trouble signals. Points can be monitored at generator or transfer switch.

12.2. Lighting

- A. Provide lighting photocell on north wall of building. Locate away from exterior lighting.
- B. When exterior light levels drop below 3 footcandles (adj), enable exterior lights. When light levels rise above 9 footcandles (adj), disable exterior lights.

12.3. IT Room Space Temperature

- A. Provide space temperature sensor in IT room. When temperature rises above 80°F (adj), generate alarm.

12.4. Solar Array

- A. Note: solar array has a stand-alone control system with monitoring, trending, and alarm capabilities. In general, this is a robust system which does not require full integration and duplication within the BAS. However, to simplify the alarm routing, it is desired to pull an alarm from the solar array and route through the BAS (in lieu of the solar array vendor).
- B. Monitor solar array alarm contact. Generate alarm on solar array contact closure.

12.5. Domestic Hot Water

- A. Monitor DHW supply temperature. If the DHW temperature rises 5°F (adj) above or below the setpoint of 116°F (adj), generate an alarm. Alarm shall be in addition to any factory provided alarms.
- B. Domestic Hot Water (DHW) recirculation pump(s) will run continuously. Determine pump(s) status through a current sensor. If a pump(s) fails to start as commanded, generate an alarm. Provide motor rated relay with HOA.

12.6. Oil/Water and Grease Separator Alarms

- A. Monitor oil/water separator and grease separator alarm panels. Wire to auxiliary contacts and generate alarm on contact closure. Single point may be used for both separators.

12.7. Outside Air Temperature and Humidity

- A. Provide combination outside air temperature and humidity combination sensor on north wall of building. Locate away from sources which will impact readings (sun, exhaust, wind, etc).

Commented [CL3]: If the temp ever gets over 72, alarms should go off. These rooms normally stay between 66 and 68 degrees.

Attachment B

23 09 00 - BUILDING AUTOMATION SYSTEMS SPECIFICATIONS

PART 1 - GENERAL

1.1. RELATED DOCUMENTS

- A. See Drawings and Specifications Binder for additional Scope of Work and other requirements.

1.2. DEFINITIONS AND ABBREVIATIONS

- A. BAS Component: a generic reference to any hardware component which is provided by the contractor, including but not limited to controllers, power supplies, transformers, relays, actuators, sensors or other devices.
- B. Building-Level Controllers: Controllers which are at, and controlling at, the level of the building. Could also be a large portion of a building, such as a wing, depending on hardware capability. Generally, are the middle tier of the overall BAS network, and report up to a supervisor. Also, generally what Device-Level Controllers would be integrated with. See Part 4 – Figures for additional clarification.
- C. Building-Level Network (BLN): See System Architecture section for full definition and specification.
- D. Building-Level Supervisor: Server which is at, and controlling at, the level of a building. Generally used when Building-Level Controllers do not have sufficient hardware capability to support an entire building. Generally, are the middle tier of the overall BAS network, and installed on a server in lieu of being a stand-alone piece of hardware. Also, generally what Building-Level Controllers would be integrated with. Building-Level Supervisors may be further integrated to an Enterprise-Level Supervisor. See Part 4 – Figures for additional clarification.
- E. Device-Level Controllers: Also referred to as Field-Level Controllers. Controllers which are at, and controlling, at the level of a device. Device in this instance is understood to reference MEP Equipment. Generally, are the lowest tier of the overall BAS network, and report up to a Building-Level Controller. See Part 4 – Figures for additional clarification.
- F. Device-Level Network (DLN): See System Architecture section for full definition and specification.
- G. Enterprise-Level Supervisor: Server, which is at, and controlling at, the level of an enterprise. Generally, are the highest tier of the overall BAS network and installed on a server in lieu of being a stand-alone piece of hardware. Also, generally what Building-Level Controllers and/or Supervisors would be integrated with. See Part 4 – Figures for additional clarification.
- H. Field-Level: See Device-Level Controllers and Device-Level Network.
- I. Furnish: To supply and deliver to project site, ready for installation.
- J. Install: To place in position for service or use.
- K. MEP: Mechanical, electrical, and plumbing.
- L. MEP Equipment: Where MEP Equipment is used, it is understood to mean any piece of MEP Equipment which the BAS will in some way, shape or form, interface with, via hardwired connection or integration. MEP Equipment includes but is not limited to

VAV, AHU, RTU, split systems, hot water heaters, heat exchangers, boilers, chillers and pumps.

M. Supervisor: See Building-Level Supervisor and Enterprise-Level Supervisor.

N. Provide: To furnish and install, complete and ready for intended use.

1.3. GENERAL SPECIFICATIONS

A. Substitutions

1. Wherever the words “for review” or “for acceptance” are used in regard to manufactured specialties, or wherever it is desired to substitute a different make or type of apparatus for that specified, submit all information pertinent to the adequacy and adaptability of the proposed apparatus to the Owner’s Representative and secure their approval before the apparatus is ordered.

B. Warranty

1. The entire BAS and all ancillary equipment required for its operation shall be free from defects in workmanship and material under normal use and service. If within 12 months from the date of substantial completion the installed equipment is found to be defective in operation, workmanship or materials, the Contractor shall replace, repair or adjust the defect at no cost to the Owner.
2. The warranty period for work and systems of this project shall commence after written notification of Owner’s final acceptance.
3. Corrective software modifications made during warranty service periods shall be updated on all user documentation and on user and manufacturer archived software disks.
4. The Owner reserves the right to make changes to the BAS during the Warranty Period. Such changes do not constitute a waiver of warranty. Contractor shall warrant parts and installation work regardless of any such changes made by Owner unless the Contractor provides clear and convincing evidence that a specific problem is the result of such changes to the BAS.
5. At no cost to the Owner, during the Warranty Period, Contractor shall provide maintenance services for software including all current software updates, firmware and hardware. Prior to the closeout of the warranty period, the BAS contractor shall meet with the owner’s representative to address any questions or concerns and offer ongoing Software Maintenance Services to the owner.
6. Electronic Actuators: Parts and labor for 5 years from the date of substantial completion.

C. Training

1. Provide four hours of training for facility personnel, and/or maintenance contractor, on the operation and maintenance of the system.

1.4. DESCRIPTION OF WORK

- A. Contractor shall provide all hardware, software, configuration, programming, graphics (GUI), checkout, alarms, trending, and commissioning necessary to provide a complete and functioning system as specified. Contractor shall include all hardware, software and programming not specifically itemized in these Specifications, which is necessary to implement, maintain, operate, and diagnose the system, now and in the future, in compliance with these Specifications.
- B. This project requires the installation of a new Building Automation System (BAS) constructed using a Niagara Framework with BACnet MS/TP or IP Device-Level

Controllers for the MEP Equipment identified in the Contract Documents. The new BAS shall utilize one or more JACE 8000 controllers, networked with a Niagara Framework Web Supervisor.

- C. Niagara Framework will be Niagara 4, with the latest stable released installed (as identified by the contractor).
- D. It is the Contractor's responsibility to review all of the Contract Documents and report any discrepancies to the Owner.

1.5. CONTROL DIAGRAMS, SEQUENCE OF OPERATION, AND POINTS LISTS

- A. Provide all necessary hardware on each piece of MEP Equipment in order to:
 - 1. Perform the specified sequence of operation and meet the design/performance intent of the MEP Equipment,
 - 2. Comply with components as shown on the control diagrams,
 - 3. Meet the requirements of the point lists, or,
 - 4. Comply with the specifications herein.
- B. Where the sequence of operation, control diagrams, points list or specifications are in conflict with each other, Contractor will comply with the most stringent requirement.
- C. Program each BAS component to perform the sequence of operation.
- D. The Contractor shall be responsible for all control wiring connections, auxiliary devices, and control wiring diagrams, to complete the control system and attain the described sequence of operation.

1.6. CODES AND REFERENCE STANDARDS

- A. Comply with all current codes, ordinances, regulations, and the Town of Morrisville requirements.
- B. The latest published edition of a reference shall be applicable to this Project unless identified by a specific edition date.
- C. All materials, installation and workmanship shall comply with the applicable requirements and standards addressed within the following references:
 - 1. American Society of Heating, Refrigeration and Air Conditioning Engineers (ASHRAE)
 - 2. American National Standards Institute (ANSI)
 - 3. UL 916: Energy Management Systems
 - 4. LonMark International
 - 5. BACnet Testing Lab

1.7. COORDINATION OF WORK AND INTEGRATION

- A. Certain LonMark, BACnet, Modbus, and other products, systems and interface devices, may be provided by other trades via MEP Equipment. Examine the Contract Documents to ascertain the requirements to install, wire, program, commission, and/or interface to these systems. Particular attention must be paid towards the interface boards submitted by the various MEP Equipment providers. It is the Contractor's responsibility to verify the submitted interfaces will integrate properly into the BAS. Report any discrepancies to the Owner. Discrepancies brought to the Owner's attention after the procurement of that piece of MEP Equipment will be integrated at no additional cost to the owner. Contractor will provide additional interface(s) needed to integrate piece of MEP Equipment.

Commented [CL4]: We always get beat up when we specify a certain make or model of a piece of equipment. To get around it, we add the phrase "or equivalent".

- B. In addition to the Owner's representative, Contractor shall review MEP Equipment for compliance with control diagrams, sequence of operation, and points lists. Report any discrepancies to the Owner.
- C. Wherever work interconnects with work of other trades, coordinate with other trades and with the Owner's representative to ensure that all trades have the information necessary so that they may properly install all the necessary connections and equipment.
- D. Coordinate location of thermostats, humidistats, and other exposed control sensors with plans and room details before installation. Verify all locations with Engineer and/or General Contractor prior to installation.
- E. Coordinate sources of 120V power with the Electrical Contractor and Owner. Extend power from sources as needed.
- F. Coordinate location of data ports/drops with the Electrical Contractor and Owner.

1.8. SPARE PARTS

- A. Furnish extra materials that match products installed and that are packaged with protective covering for storage and identified with labels describing contents.
- B. Provide one replacement for each unique actuator, controller, thermostat, wall module, or any other BAS component provided.

1.9. QUALITY ASSURANCE

- A. All microprocessor-based control products used shall conform to LonMark Certified Interoperability Standards, BTL Certified Standards, Modbus communication standards and/or Niagara Framework. Components will be marked with the LonMark and/or BTL certified logos. Building and/or Network-Level Servers will be BACnet BTL AWS listed.
- B. The BAS and components shall be listed by Underwriters Laboratories (UL 916) as an Energy Management System.
- C. Control panels, both new and modified, shall comply with UL 508A.
- D. Electrical Components, Devices, and Accessories: UL listed and labeled as defined in NFPA 70.

1.10. **CONTRACTOR QUALIFICATIONS**

- A. Qualifications may be requested from Contractor prior to the bidding process. Owner reserves the right to not allow Contractors to bid if they do not meet the qualifications or provide them in a timely manner. Qualifications will be provided for all items below in an orderly format for review by the Owner and Owner's representative.
- B. The Contractor shall have a successful history in the design and installation of Niagara Framework for Enterprise connectivity BAS that consists of web-browser monitoring and control of LonWorks, BACnet and/or Modbus Device-Level Controllers. These projects must be on-line and functional such that representatives from the Owner can observe the BAS and Interface in full operation. Include proper references and contact numbers of these reference projects.
- C. Contractor must demonstrate experience in BAS installations for not less than five years, in BAS installation projects with point counts equal to this Project, and systems of the same character as this Project.
- D. Contractor shall have specialized in and be experienced with the installation of the proposed product line for not less than five years, on at least ten projects of similar size

Commented [CL5]: Anything non-technical we put into a town contract should most likely be reviewed by Town Legal. Just a thought.

and complexity. Submittals shall document this experience with references, upon request. Contractor shall be factory authorized in good standing with the manufacturer.

- E. Contractor shall be located within 50 miles of the project site. Have a minimum of three, Niagara TCP certified personnel.
- F. Have a minimum of three personnel who are certified in LonWorks, BACnet, and/or Modbus line(s) of controls to be installed as part of this project.

1.11. SUBMITTALS

- A. Product Data: Submit manufacturer's technical product data for each Niagara Framework based controller, control device, sensor, actuator, relay, panel, and any other BAS Component, indicating dimensions, capacities, performance and electrical characteristics, and material finishes. Also include installation and start-up instructions.
 - 1. When manufacturer's product datasheets apply to a product series rather than a specific product model, clearly indicate and highlight only applicable information.
- B. Submit documentation indicating LONMARK®, NICs and/or BTL compliance and include Protocol Implementation Conformance (PIC) Statements.
- C. Submit Shop Drawings for each control system. Shop drawings will include:
 - 1. Bill of Materials (BOM): indicating equipment served, quantity, manufacturer, point range (i.e. 0-10 in. w.c.), sensor range (i.e. 0-10V), and model number for all BAS Components being provided.
 - a. Disconnect Schedule: additionally, indicating MCA, MOP, voltage, # of phases, size, NEMA rating, # of poles, and neutral (Y/N).
 - b. Starter Schedule: additionally, indicating horsepower, voltage, # of phases, size, NEMA rating, and bypass.
 - c. VFD Schedule: additionally, indicating horsepower, voltage, # of phases, size and NEMA rating, bypass (Y/N), number of contactors (if bypass), disconnect (Y/N), and disconnect type (fused/non-fused).
 - d. Hydronic Valves (Pressure-Dependent): additionally, indicating gpm, line size, calculated Cv and design pressure drop, actual Cv and actual pressure drop, close-off pressure, type (ball/globe/butterfly), connection, valve size, 2/3-way, mixing/diverting (if 3 way), service (2-position/modulating), and fail position.
 - i. Actual pressure drop will correct for any line-size to valve-size restrictions per the manufacturer's data.
 - ii. Actuator will be scheduled with the valve per the standard BOM.
 - e. Hydronic Valves (Pressure-Independent): additionally, indicating gpm, line size, selected valve gpm, maximum valve gpm, min/max pressure drops, close-off pressure, type (ball/globe/butterfly), connection, valve size, 2/3-way, mixing/diverting (if 3 way), service (2-position/modulating), and fail position.
 - i. Actual pressure drop will correct for any line-size to valve-size restrictions per the manufacturer's data.
 - ii. Actuator will be scheduled with the valve per the standard BOM.
 - f. Steam Valves: additionally, indicating lb/hr, inlet pressure, outlet pressure, line size, calculated Cv and design pressure drop, actual Cv and actual pressure drop, close-off pressure, type (ball/globe/butterfly), connection, valve size, 2/3-way, mixing or diverting (if 3 way), service (2-position/modulating), and

- fail position.
- i. Actual pressure drop will correct for any line-size to valve-size restrictions per the manufacturer's data.
 - ii. Provide sizing methodology/calculations for manufacturer selected.
 - iii. Actuator will be scheduled with the valve per the standard BOM.
- g. Air Flow Metering Stations (AMFS): additionally, indicating duct size, output, network capable (LON/BACnet), and number of probes/sensors.
 - h. Water/Steam Flow Meters: additionally, indicating line size, output, network capable (LON/BACnet), and flow meter style/type.
 - i. Damper Schedule: additionally indicating, duct size, blade type, leakage and construction.
 - j. VAV schedule: indicating VAV type, K factor, and max/min/reheat flows.
2. Schematic Flow Diagram: schematic representation of MEP Equipment. Diagram will show all BAS Components on schematic, point name, and point number (i.e. UI-1). Where MEP Equipment varies slightly, schematic will be clearly diagrammed to indicate any differences between each piece of MEP Equipment. Stating the schematic as "typical" is not acceptable.
 3. Wiring Diagram: indicating power, signal, and control wiring. Where terminal blocks are provided, provide indication where wiring terminates to terminal block.
 4. Sequence of Operation: Any modifications proposed to the sequence of operation will be clearly marked up as part of the shop drawings or submitted as an annotated Microsoft Word document in addition to the shop drawings. A default contractor sequence of operation, included without regard to the Engineer's sequence of operation, will result in a rejected submittal.
 5. Control Panel Diagrams: indicating panel faces, BAS Component locations inside panel, and labeling of BAS Components.
 6. One-line diagram indicating how the new Niagara Framework network controllers will integrate with the new and/or existing BAS devices.
 7. Indicate anticipated device ID, Network number, MAC Addressing, and Max Masters for all BACnet devices. Provide logical schema for BACnet addressing.
 8. Individual floor plans with device (controllers, routers, sensors, etc.) locations with all interconnecting wiring routing including space sensors, Device and Building-Level Network wiring, power wiring, and low voltage power wiring.
 9. Additional Requirements:
 - a. Point names will be consistent between the schematics and wiring diagrams.
 - b. Misc. Points List: where controllers being provided for other purposes are also used to control a miscellaneous point, such as an exhaust fan or lighting contactor, provide a list of those miscellaneous points in a concise format for quick identification of their location and associated controller.
 - c. Provide a complete list of any deviations of submitted products to the specification in this document.
- D. Submit a BAS Start-Up Test Agenda and Schedule/Sequence of Construction, as it pertains to the installation of the BAS, for review and approval.
 - E. Graphics Submittal

1. Provide screen captures of graphical user interfaces developed by the Contractor on previous projects. These screen shots shall represent work performed by the contractor and not of the company from the line of controls which the Contractor represents. Screenshots will be applicable to the MEP systems as part of this project. "Generic" screenshots of MEP systems will not be accepted. Provide client contact information for the Owner to validate. Any comments from the submittal process will be incorporated into the actual graphics for the project.
2. Follow the Owner's graphics standards.

F. Point Naming Convention

G. Checkout Sheets

1. Prior to startup of any equipment, contractor will provide checkout sheets for each piece of equipment.
2. Checkout sheets will contain at a minimum:
 - a. Equipment name and location.
 - b. Associated controller address (MAC or Node ID), name, type and instance number.
 - c. Checking, adjusting and calibration data.

1.12. SYSTEM ARCHITECTURE

- A. The system provided shall incorporate hardware and software resources sufficient to meet the functional requirements of these Specifications. The Building and Device-Level Network shall be based on industry standard open platforms as specified herein and utilize commonly available operation, management and application software. All software packages and databases shall be licensed to the Owner to allow unrestricted maintenance and operation of the BAS. Contractor shall include all items not specifically itemized in these Specifications that are necessary to implement, maintain, and operate the system in compliance with the functional intent of these Specifications.
- B. The system architecture shall be based on the Niagara Framework and consists of a Wide Area Network (WAN), a Local Area Network (LAN), a Building-Level Network and one or more Device-Level Network(s), as applicable.
 1. Wide Area Network (WAN): Ethernet-based network which connects multiple facilities via the internet. This is an existing infrastructure provided by the Owner, and Contractor is not required to configure any components of this WAN.
 - a. The existing WAN infrastructure shall be used to connect the Enterprise-Level Supervisor to the BAS.
 2. Local Area Network (LAN): Ethernet-based and wireless network which connects computers and other internet/ethernet devices (printers, etc), and has a connection to the WAN. This is an existing infrastructure provided by the owner, and Contractor is not required to configure any components of this LAN.
 - a. The existing LAN infrastructure shall be used to connect the Building-Level Controller(s), Building-Level Supervisor and shall be the connection point to the WAN for the BAS.
 3. Building-Level Network (BLN): An ethernet-based and wireless network as part of the LAN, which has been segmented to be used exclusively by the BAS. Any BAS component requiring an ethernet/IP connection, and not specifically allowed to connect to the Owner's LAN/WAN as called for above shall be required to connect the BLN.
 - a. The BLN shall be consistent with the Owner's requirements, and at a minimum IEEE 802.3 Ethernet over Fiber or Category 6 cable with switches and routers

that support 1000base-T gigabit Ethernet throughput.

- b. The BLN is not required if no additional BAS components require an ethernet/IP connection.
 - c. Prior bidding, where there is a desire to connection to the BLN, contractor will obtain permission to connect in a hardwired or wireless fashion. Contractor will provide a document with necessary connections and locations of hardwired ethernet drops for consideration by the Customer prior to approval of connections.
 - d. New Construction: The LAN will be under construction and not necessarily complete prior to BAS completion. As such, a temporary BLN will be provided by the Contractor for functionality of the system. This may include wireless access points, switches, or other temporary hardware for full functionality. Upon completion of the LAN, which will also serve as the BLN, the Contractor shall remove the temporary equipment and provide final installation of devices to the permanent BLN. Testing of the system will be provided to ensure functionality is the same as on the temporary system.
 - e. Renovation: provide temporary hardware as required by the Town. In some cases, the LAN will be complete and temporary hardware will not be required. In some cases, the LAN may require modification to provide the BLN and temporary hardware is necessary. Coordination up-front prior to bid is required by the contractor.
 - f. Note the temporary BLN may not be required when the DLN serves as the primary communication system for BAS devices.
4. Device Level Network (DLN): Network used to connect Device-Level Controllers to Building-Level Controllers. Also commonly referred to as Field-Level Controllers and Field-Level Network.
- a. Network shall be consistent with communication protocol as listed in Description of Work.
 - b. Where DLN is an ethernet-based network (vs traditional copper twisted-pair network), the requirements of the BLN shall also apply to the DLN.
5. ARCnet and/or Token-Ring based BLNs and DLNs shall not be acceptable.
- C. The communication speed between BAS components shall be sufficient to ensure fast system response time under any loading condition. At a minimum, network speed shall be <78K bits per second (LonWorks), 19.2K bits per second (MODBUS), 76,800 baud (BACnet)>.
- D. The Contractor may request, prior to the bidding process, additional connections to the WAN/LAN beyond the ones specified herein. Should those connections be disallowed, the contractor shall provide a BLN at no additional cost to the Owner.
- E. Capacity of any Building or Device-Level Network shall be limited to 70% of the allowable device count to allow for future minor modifications or expansions to the network. Provide calculations on request.

1.13. MATERIALS AND EQUIPMENT

- A. All materials shall meet or exceed all applicable referenced standards, federal, state and local requirements, and conform to codes and ordinances of authorities having jurisdiction.
- B. Materials shall be new, the best of their respective kinds without imperfections or blemishes and shall not be damaged in any way. Used equipment shall not be used in

also be constructed in a modular fashion to permit the next generation and support components to be installed in replace of or in parallel with existing components.

- E. The Contractor shall furnish and install single controllers with the physical and software resource count for standalone operation of each piece of equipment. The sequence of operation and required points for control shall reside on a single controller. Remote I/O modules (via a field wired communications bus) are not acceptable for points required to achieve the sequence of operation. Expansion I/O modules plugged directly into the controller may be utilized for expansion.
- F. Controllers shall have the ability to perform energy management routines via preprogrammed function blocks or template programs.
- G. Remote data access: The system shall support the Internet Browser-based remote access to the building data. The BAS contractor shall coordinate with the Owner's IT department to ensure all remote browser access is protected with the latest Niagara Software updates and a VPN (Virtual Private Network) must be installed to protect the owner's network from cyber-attacks.
- H. Browser-based access: A remote/local user using a standard browser will be able access all control system facilities and graphics via the WAN or direct connection, with proper username and password. Only HTML5 browser-based graphical user interfaces (GUI) is acceptable. The system shall be capable of supporting an unlimited number of clients using a standard Web browser such as Internet Explorer™, Firefox™ or Chrome™.
- I. Niagara Framework Control Systems Server (CSS): A server that maintains the systems configuration and programming database. It shall allow secure multiple access to the control information.
- J. Systems Configuration Database: The system architecture shall support maintaining the systems configuration database on a Supervisor server on the LAN. User tools for BLN and/or DLN management shall be provided and licensed to the Owner and shall allow unrestricted configuring, updating, maintaining, and expanding of all current devices, configurations and settings.
- K. Database Schema shall be published and provided to the Owner to facilitate easy access to BLN and DLN data.
- L. Device Count and Software Maintenance Agreements
 - 1. All Controllers and Supervisors which have a license structure to where only a certain quantity of BAS Components or devices can connect to it shall be selected such that there is a minimum 25% capacity for future BAS Component or device connections. (i.e. if there are 80 connected devices, the license shall allow for $80 \times 1.25 = 100$ potential device connections (20 extra device connections possible).
 - 2. All Controllers and Supervisors which have a license structure requiring a Software Maintenance Agreement (SMA) shall be for a period of five years.

2.4. SYSTEM PERFORMANCE

- A. Description: The BAS shall comply with the following minimum performance requirements:
 - 1. Graphic Display: Display graphic with minimum 20 dynamic points with current data within 10 seconds.
 - 2. Graphic Refresh: Update graphic with minimum 20 dynamic points with current data within 8 seconds.
 - 3. Object Command: Reaction time of less than 2 seconds between operator command of a binary object and device reaction.

4. Object Scan: Transmit change of state and change of analog values to control units or workstation within 6 seconds.
5. Alarm Response Time: Annunciate alarm at workstation within 45 seconds. Multiple workstations must receive alarms within five seconds of each other.

2.5. DEVICE-LEVEL CONTROLLERS

A. General

1. Provide BACnet Controllers that are BACnet Testing Laboratory listed (v12 or later) as specified herein:
 - a. BACnet Building Controller (B-BC)
 - b. BACnet Advanced Application Controller (B-AAC)
 - c. BACnet Application Specific Controller (B-ASC)
2. Device Level Controllers shall fundamentally communicate with the protocol as specified in the Description of Work. Field Controllers which communicate over a non-specified protocol and then convert to a specified protocol via a protocol converter, router or gateway are not acceptable.
3. All controllers shall be able to communicate peer-to-peer without the need for a Building- Level Controller (JACE) and shall be capable of assuming all responsibilities typically assumed by a Building-Level Controller. Any controller on the Ethernet Data Link/Physical layer shall be able to act as a Master to allow for the exchange and sharing of data variables and messages with any other controller connected on the same communication cabling. Slave controllers are not acceptable.
4. Device Level Controllers will be provided for all large pieces of MEP Equipment. Controller "sharing," where one controller does one or more pieces of MEP Equipment, is not allowed, unless specifically approved by the Engineer.
5. Each Controller shall have a minimum of 10% spare capacity for each point type for future point connection, rounded to the nearest whole number.
6. Performance
 - a. Each BACnet controller shall have a minimum of 64KB of RAM and 384KB of non-volatile flash memory.
 - b. Each controller shall have a 32-bit microprocessor operating at a minimum of 68 MHz.
 - c. Real time clock with rechargeable battery and 20 days power backup.
7. Each BACnet controller on the BACnet MS/TP communications trunk shall provide a loading characteristic of minimum 1/8th Load.
8. The control program shall be resident within the same enclosure as the input/output circuitry, which translates the sensor signals. The control program shall be stored in non-volatile memory, which is not dependent upon the presence of a battery, to be retained.
9. Device-Level Controllers shall communicate on a hardwired bus. Where wireless controllers are desired, they shall be submitted as an approved alternate prior to bid. Wireless controls require upfront coordination with the Town IT Department. This shall be done prior to bid.

B. Configurable Controllers

1. Shall contain an application-specific control program which can be configured to meet the sequence of operation as specified.

2. Where a configurable controller cannot be configured to meet the sequence of operation as specified, a programable controller will be used. Alternatively, the Contractor may submit a request to modify the sequence of operation so that a configurable controller may be used in lieu of programmable.

C. Programable Controllers

1. Shall be fully programmable and the programming software shall have a library of pre- built, tested, and user re-definable control sequences for a wide range of typical HVAC applications.

2.6. BUILDING-LEVEL CONTROLLERS

- A. Building-Level Controller shall be JACE 8000 series.

2.7. BUILDING AND ENTERPRISE-LEVEL SUPERVISORS

- A. The existing enterprise-level supervisor will be used for all Town of Morrisville projects. See requirements for coordination regarding the Master System Integrator (MSI) in 3.3.

2.8. SOFTWARE

- A. The Owner shall be the named license holder of all software associated with any and all incremental work on the project. Contractor will coordinate with Owner IT for any requirements regarding software/hardware licensing.

2.9. CONTROL PANELS

- A. Control panels are an assembly composed of an enclosure and one or more BAS Components. Control panels will be provided for all MEP Equipment which requires a controller(s) and does not have an enclosure for a controller included with the MEP Equipment.
- B. Controllers installed inside of MEP Equipment shall only be done so in spaces designed for a controller to be installed, such as a VAV controls enclosure. Just because a controller fits inside does not constitute being designed for a controller to be installed. Controller shall not be installed on the outside of any MEP Equipment or in a plenum, even if controller is plenum rated.
- C. Enclosures shall have continuously welded and ground smooth seams, have doors that open 180 degrees, concealed and continuous hinge, and ground studs on door and body.
- D. Indoor/inside control panel enclosures shall be NEMA/UL Listed Type 1. Enclosure shall be powder-coated steel in a blue color. Outdoor/outside control panel enclosures shall be NEMA/UL Listed 3R or 4X. Enclosure shall be power-coated steel in a gray color or stainless steel.
- E. All enclosures will be provided with a removable backplate to which BAS components will be fastened. No BAS components will be fastened to the enclosure body. BAS components, such as pilot lights and switches, displays, operator interfaces, may be mounted to the enclosure door, so long as they are designed to do so. No component will sacrifice or downgrade the NEMA rating of the enclosure.
- F. Control panels will be sized (width, height, and depth) so that all controllers and other components, including but not limited to relays, power supplies and transformers, fit inside neatly and in an organized fashion. Provide cable tray for all wire to rest in and fasten to backplate.
- G. Control panels which have more than one BAS Component are required to be provided prewired to numbered terminal blocks. All BAS Components and terminal blocks will be fastened to the removable backplate and wired between the BAS components and

terminal block at the Contractors panel shop. The terminal block will serve as the demarcation point between factory/shop wiring and field wiring. At no point shall field wiring cross the terminal block and be wired directly to a factory/shop installed component. Any BAS component that was intended to be in the field, such as a relay, will not be installed inside the control panel enclosure.

1. Exception: control panels which house only one BAS Component, such as a controller, are not required to have numbered terminal blocks, and may have field wiring terminated directly to the BAS Component.
- H. The design intent of the control panels is to have the ability to, in the future, disconnect all field wiring from the terminal blocks, remove the backplate with old control components, install new backplate with new control components and reconnect wire to the terminal blocks. Contractor will maintain design intent with their panel design and installation.
- I. Contractor shall extend power to the control panel from an acceptable power panel (coordinate with Division 26 and/or Owner).

2.10. UNINTERRUPTABLE POWER SUPPLIES

- A. Provide individual UPS to maintain system operation for short-term power interruptions up to 30-minutes. Manufactured by APC or Engineer approved equal. Provide UPS for operator workstations, servers and Building-Level Controllers.

2.11. SENSORS AND DEVICES

A. General

1. Provide sensors as indicated in control diagrams and sequences of operation, or as needed to perform the intended operations.
2. Provide with metal enclosure for all plenum applications. Any sensor mounted in plenum that has a plastic enclosure will be rated for plenum installation or installed in a plenum- rated enclosure.
3. All sensors shall be vibration and corrosion resistant.
4. Accuracy statements are written for the specific sensor. Installation shall not degrade accuracy more than double what accuracy statement for sensor requires.
5. Enclosures:
 - a. Provide suitable enclosure for sensor/device/actuator/etc for ambient conditions encountered by application.
 - b. NEMA Type 1 or 2 for indoor and protected applications.
 - c. NEMA Type 3R, 4 or 4X for outdoor and unprotected applications.

B. Temperature Sensors

1. Manufacturers:
 - a. Distech
 - b. JCI
 - c. BAPI
 - d. ACI
 - e. Honeywell
2. General Requirements:

- a. Sensor shall be thermistor or RTD inherently compatible with BMS.
 - b. Accuracy: Plus or minus 0.5 deg F over 32 to 158 deg F range.
 - c. Operating Temperature Range: -40-300 deg F
3. Outside Air Temperature (OAT) Sensor: Sensor installed in wall-mounted weatherproof enclosure with conduit entrance and aluminum LB with PVC sun and windscreen.
 4. Duct-Mounted Single-Point Temperature Sensor: Rigid sensor sealed in 0.25-inch stainless steel probe of length between one-third and two-thirds of the duct width in duct-mounted metal housing with conduit entrance.
 - a. Single-point may be used in ducts where there is no air stratification possibilities. Sensor shall be mounted sufficiently downstream to allow for sufficient mixing.
 5. Wall-Mounted Flat-Plate Temperature Sensor: Stainless steel, flat plate sensor that fits in a standard 2-inch by 4-inch junction box with tamperproof screws. Provide with insulated back.
 6. Strap-On Piping Temperature Sensor: Sensor with metal clamps to fasten to piping. Strap-on sensors are only acceptable where specifically called for on the Drawings. Thermowell and insertion sensor shall be installed where strap-on not specifically called for.
- C. Humidity Sensors
1. Manufacturers
 - a. Distech
 - b. JCI
 - c. BAPI
 - d. ACI
 - e. Honeywell
 2. General Requirements:
 - a. Laser-trimmed thermoset polymer-based capacitive-type sensor, 4-20mA or 0-10Vdc output proportional to relative humidity range of 0% to 100% and compatible with BMS and 24 Vac/dc power supply.
 - b. Accuracy: Plus or minus 3 percent over 10 to 90 percent range.
 - c. Measurement Range: 0-100%
 - d. Operating Temperature Range: -40 to 140 deg F.
 3. Outside Air Relative Humidity (OAH) Sensor: Sensor installed in wall-mounted weatherproof enclosure with conduit entrance and aluminum LB with PVC sun and windscreen.
 4. Wall-Mounted Relative Humidity Sensor: Sensor in white plastic enclosure with insulated back.
- D. Combination Relative Humidity and Temperature Sensors
1. Where there is a requirement for the monitoring of both relative humidity and temperature at the same location, provide combination relative humidity and temperature sensors. The individual sensors must each meet the specifications details herein.

2. Where required in the drawings, combination relative and humidity sensors shall have the ability to output additional parameters, including dew point, enthalpy and wet bulb temperature.
- E. Wall Modules and Room Sensors
1. General
 - a. Wall modules and room sensors cover devices which mount on a wall and provide an interface between the HVAC system/zone and the occupant.
 2. Manufacturers: Provide a wall module consistent with the manufacturer providing the overall controls.
 3. General Requirements:
 - a. Wall modules which measure including but not limited to temperature, relative humidity and/or carbon dioxide must each meet the specifications details herein.
 - b. Provide with plastic enclosure with display, override switch, override indicator, and set point adjustment.
- F. Current Switches/Transducers
1. Manufacturers
 - a. ACI
 - b. Veris
 - c. Setra
 2. General Requirements
 - a. Sensor shall be rated for their associated motor load and voltage, have input and output isolation, and have LED indication of status.
 - b. Sensor shall be selected based on application, including but not limited to standard 60 hertz motors, variable speed drive or ECM.
 - c. Accuracy: 2 percent of full scale output.
 - d. Measurement Range: 0 to two times the anticipated current.
 - e. Operating Temperature Range: 5 to 140 deg F.
 3. Current Switch: Self-powered current switch with N.O. contacts. Provide with adjustable trip point where applicable.
 4. Current Transducer: Sensor with 4-20 mA, or 0-10Vdc output proportional to current draw.
- G. Relays
1. Manufacturers
 - a. IDEC
 - b. Functional Devices
 - c. Veris
 2. General Requirements
 - a. Electrically rated for application, minimally SPDT with 10A (resistive) contacts.
 - b. Provide with LED indicator light.

- c. Provide with hand-off-auto (HOA) unless otherwise specified.
 - d. Plenum rated where required.
 - 3. BAS Panel-Mounted Relays: “ice-cube” / socket style with mounting base and replaceable relay. Relays in panel will be screw terminal terminations; relays with wiring whip from factory are not allowed for panel mounting. HOA not required if controller has internal HOA or output being controlled has HOA (i.e. VFD).
 - 4. Nipple-Mounted Relays: enclosed relay compatible with conduit knockout. Acceptable for field use. With or without factory-provided wiring whip. HOA not required if output being controlled has HOA (i.e. VFD).
 - 5. Track-Mounted Relays: acceptable for use in terminal unit control panels. Screw terminal terminations. Track-mounted relays are not to be installed in field unless inside an equipment control panel (no track-mounted relays in electrical boxes). HOA not required if output being controlled has HOA (i.e. VFD).
 - 6. Combination Motor Starter / Current Switch Relays: allowed only for single-phase equipment and must be mounted such that pilot light is exposed (combination motor starter / current switch relays which install inside of motor starter/VFDs are not allowed). Relay and current switch must each meet the specifications details herein. HOA not required if output being controlled has HOA (i.e. VFD).
- H. Carbon Dioxide Sensors
- 1. Manufacturers
 - a. Honeywell
 - b. Veris
 - c. Vaisala
 - 2. General Requirements
 - a. Non-dispersion infrared (NDIR) type sensor, 4-20mA or 0-10Vdc output proportional to carbon dioxide (CO₂) range and compatible with BMS system and 24 Vac/dc power supply.
 - b. Sensor shall have local display.
 - c. Accuracy: Plus or minus 2 percent of reading, or 30 ppm, whichever higher.
 - d. Measurement Range: 0 to 2000 ppm.
 - e. Operating Temperature Range: 32 to 122 deg F.
 - f. Standard Calibration: No maintenance or periodic sensor replacement needed. The sensor shall have a 5-year calibration interval, utilizing an automatic unoccupied period calibration.
 - g. Where the building operates 24 hours per day (no unoccupied periods), sensors capable of maintaining accuracy without the automatic unoccupied period calibration sequence will be installed.
 - 3. Wall-Mount Carbon Dioxide Sensors: Sensor with plastic enclosure that fits on a standard 2-inch by 4-inch junction box.
 - 4. Duct-Mount Carbon Dioxide Sensors: Sensor with sampling tube, duct-mounted metal housing with conduit entrance.
 - 5. Where CO₂ is provided beside temperature and or humidity sensors, it shall be provided separately and not combined into a single sensor.
- I. Additional Instrumentation and Sensors

1. Shaft-Mounted Limit Switches: SPDT/DPDT mercury-free, gravity-actuated mechanical switch with adjustable shaft connection.
 2. Whisker Limit Switches: SPDT/DPDT mechanical whisker switch with adjustable trim arm.
 3. Control Transformers: Class 2, sized and rated for application. Circuit breaker overcurrent protection: fused or internal overcurrent protection is not allowed. Transformers shall be sized so that connected load does not exceed 75 percent of rating. Functional Devices TR series or equal.
 4. Condensate Drain Pan Overflow Safety Switch: Low-voltage, float-type safety switch designed for condensate drain pan high-level alarm for unit shutdown and alarming. Little Giant Pump/Franklin Electric (ACS series) or equal. Whisker switch with foam float is not acceptable.
 5. Water Leak Detection Alarm: Adjustable-height multi-point water detection sensor constructed to be corrosion and abrasion resistant and configured for normally open or normally closed as required by the application with 24Vac/dc power supply. Provide remote-mounted sensing probe and cable as needed for each application.
 - a. Operating Temperature Range: Minus 40 to positive 185 deg F.
 6. Condensate Drain Pan Overflow Safety Switch: Low-voltage, float-type safety switch designed for condensate drain pan high-level alarm for unit shutdown and alarming. Little Giant Pump/Franklin Electric (ACS series) or equal. Whisker switch with foam float is not acceptable.
 7. Emergency Stop Buttons: ADA-compliant, red emergency pushbutton in white polycarbonate plastic enclosure with clear flip-up cover and stainless steel backplate. Button shall be reset by twisting or pulling out the button; a procedure that requires disassembly or a key is not acceptable. 120V or 24 V as needed. Provide label with indication of operation. Safety Technology International (STI) Stopper Station series or equal.
- J. Electronic Actuators
1. Manufacturers: All valve actuators shall be supplied from a single manufacturer. All damper actuators shall be supplied from a single manufacturer. Provide actuators manufactured by one of the following:
 - a. Belimo
 - b. Honeywell
 - c. Johnson Controls
 - d. Schneider Electric (TAC Dura-Drive)
 2. General
 - a. Direct-coupled type designed for minimum 60,000 full-stroke cycles at rated torque.
 - b. Actuators shall operate related valve(s)/damper(s) with sufficient reserve power to provide smooth modulating action or two-position action and proper speed of response at velocity and pressure conditions to which the valve/damper is subjected.
 - c. Actuators shall produce sufficient power and torque to close off against the maximum system pressures encountered. Actuators shall be sized to close off against the designed pump/fan shutoff pressure as a minimum requirement.

- d. Select actuators to fail in desired position in the event of a power failure. See drawings for power failure modes.
- e. Provide a position indicator and graduated scale on each actuator indicating open and closed travel limits.
- f. Type: Motor operated, with gears, electric and electronic.
- g. Voltage: 24Vac unless otherwise specified. 120V actuators may be allowed if coordinated by controls contractor with electrical contractor to provide local disconnect and power. Circuit must be fed from the same power panel as the equipment or control panel and a spare circuit must be available.
- h. Power: Contractor is responsible for sizing control transformers based on the VA of the actuator(s) selected.
- i. Provide electronic overload protection throughout the entire operating range in both directions.
- j. Coupling: V-bolt and V-shaped, toothed cradle. Bolt and set screw method of attachment is unacceptable.
- k. Actuators shall be capable of being mechanically and electrically paralleled to increase torque if required.
- l. Two-Position Actuators: Single direction, spring return or reversing (non-spring return) type.
- m. Modulating Actuators:
 - i. Capable of stopping at all points across full range and starting in either direction from any point in range.
 - ii. Control Input Signal:
 - A) Three Point, Tristate, or Floating Point: Clockwise and counter-clockwise inputs. One input drives actuator to open position, and other input drives actuator to close position. No signal of either input, the actuator remains in the last position.
 - B) Proportional: Actuator drives proportional to input signal and modulates throughout its angle of rotation. Suitable for zero to 5-, zero-to 10-, 1 to 5- or 2- to 10-Vdc and 4- to 20-mA signals.
 - iii. Floating control actuators shall be allowed only for damper and valve control for room terminal units where there is not a room pressurization requirement. See General Requirements for definition of those spaces. Use of floating controls must be specifically requested by the contractor for specific spaces and reviewed by the engineer. Submission of floating control actuators without specific comment by the contractor for spaces and the resulting review by the Engineer does not constitute approval for use.
 - iv. Pulse width modulation (PWM), or any other analog signal that is not specified above is not allowed.
- n. Position Feedback: Where indicated, equip two-position actuators with auxiliary switches (SPDT) for remote monitoring of open and/or closed position. Point of open and/or closed position can be adjusted over the actuators range of operation (0- 100%). Where indicated, equip modulating actuators with a position feedback through current and/or voltage signal for remote monitoring.

- o. Fail-Safe: Where indicated, provide actuator to fail via a mechanical spring return mechanism, to drive controlled device to an end position (open or close) on loss of power. Electronic fail-safe is not allowed, unless specifically reviewed and accepted by Engineer. Provide external, manual gear release on non-spring-return actuators.
 - p. Temperature Rating:
 - i. Standard Dampers and Valves: Minus 22 to plus 122 deg F.
 - ii. Smoke Dampers: Minus 22 to plus 250 deg F.
 - q. Provide actuator enclosure with a heater and controller where required by application.
 - r. Stroke Time:
 - i. Normal: 120 seconds or less from fully closed to fully open, or fully open to fully closed.
 - ii. Fast-Acting: 12 seconds open, 5 seconds closed unless otherwise noted.
3. Damper Actuators
- a. The total damper area operated by an actuator shall not exceed 80 percent of damper manufacturer's maximum area rating.
 - b. Provide one actuator for each damper assembly where possible. Multiple actuators required to drive a single damper assembly shall operate in unison off a single control signal.
 - c. Avoid the use of excessively oversized actuators which could overdrive and cause linkage failure when the damper blade has reached either its full open or closed position.
 - d. Use shaft couplings in lieu of blade-to-blade linkages when driving axially aligned damper sections.
 - e. Actuator will mount directly to damper with coupler as described above. No foot mount kits, jackshafts or linkages shall be used.
 - f. Sizing: Size for running torque calculated as follows:
 - i. Parallel-Blade Damper with Edge Seals: 7 inch-lb/sqft. of damper.
 - ii. Opposed-Blade Damper with Edge Seals: 5 inch-lb/sqft. of damper.
 - iii. Parallel-Blade Damper without Edge Seals: 4 inch-lb/sqft. of damper.
 - iv. Opposed-Blade Damper without Edge Seals: 3 inch-lb/sqft. of damper.
 - v. Dampers with 2- to 3-Inch wg of Pressure Drop or Face Velocities of 1000 to 2500 fpm: Increase running torque by 1.5.
 - vi. Dampers with 3- to 4-Inch wg of Pressure Drop or Face Velocities of 2500 to 3000 fpm: Increase running torque by 2.0.

PART 3 - EXECUTION

3.1. PREPARATION

- A. Examine areas and conditions under which control systems are to be installed. Do not proceed with Work until unsatisfactory conditions have been corrected in manner acceptable to Installer.
- B. These specifications call out certain duties of the Contractor and any subcontractor(s). They are not intended as a material list of all items required by the Contract.

3.2. INSTALLATION

- A. Utilize licensed electricians for all new and retrofitted electrical distribution systems.
- B. Provide related items and work indicated in the Contract Documents. This includes all incidentals, equipment, appliances, services, hoisting, scaffolding, supports, tools, supervision, labor, consumable items, fees, licenses, etc., necessary to provide complete systems.
- C. Installation shall be in accordance with manufacturer's published recommendations and shall meet or exceed all applicable federal, state, and local requirements, referenced standards and conform to codes and ordinances of authorities having jurisdiction.
- D. Provide devices, power, fittings, sensors, controllers, wiring and accessories, which may be required but are not shown or specified.
- E. Provide all wiring required for a complete system, including communication bus, analog points, digital points, low voltage power, line voltage power, and emergency power.
- F. Furnish and install all low voltage step-down transformers with associated low voltage connections, power supplies and power/communication/input/output cabling necessary for the control system.
- G. Furnish and install conduit, junction boxes, fittings, panels, enclosures, and hardware as specified in these specifications, on the drawings and as required by Code.
- H. The Contractor shall be responsible for achieving the sequence of operations and intent of the system design.
- I. Limit Device and Building-Level Network cable lengths to no longer than 70% of the longest dimension published by the manufacturer of the cable or controller, between the most remote network nodes/controllers.
- J. Comply with all rules, guidelines and procedures defined by the owner's IT authority.
- K. Provide repair of all finished surfaces effected during installation. This includes but is not limited to carpet, drywall, paint, ceiling tiles and furniture.
- L. Provide sleeves and conduit for passage of pipes, and wiring through structural masonry, concrete walls and floors, and elsewhere for the proper protection of the BAS work. Seal as required.
- M. Splices are not permitted within the BAS Building or Device-Level Network communication cables. Only continuous bus topologies or continuous homeruns are allowed for these networks.
- N. Coordinate with Owner on quantity and location of any required ethernet/IP drops. Provide list to Owner a minimum of five business days' notice prior to needing the drop.

3.3. ROLE OF THE MASTER SYSTEMS INTEGRATOR (MSI)

- A. The intent is for the control system installed to be fully functional, with all graphics, trends, alarms, and other requirements herein to be complete by the controls contractor. To create a fully operational system, integration from the building level will be made to the supervisor by the Master Systems Integrator (MSI).
- B. In general, the JACE and associated programming to achieve the functionality as specified will be the responsibility of the controls contractor (CC). The Supervisor and the associated programming to achieve the functionality as specified will be the responsibility of the Master Systems Integrator (MSI).

- C. Coordination between the CC and MSI is critical for the success of the project.
- D. CC shall maintain consistency with standards within the specification and as established by the MSI where the specifications do not apply.
- E. A \$5,000 allowance for the MSI will be carried directly by the Town.
- F. MSI will provide any established graphics, point naming conventions, etc created for the Town at the CC's request. MSI will provide access to the Town supervisor (as required).
- G. All trends will be established within the JACE by the CC. Upon completion of trends, MSI will push trends from JACE to Supervisor for long-term storage. Alarms will be established within the JACE by the CC. Upon completions of alarms, MSI will push alarms to master supervisor alarm console (existing alarm console for master supervisor previously installed as part of previous BAS project) for classification and dispatch to users.
- H. Graphics will be installed on the JACE by the CC. Upon completion of graphics, MSI will create a point on Supervisor to navigate to JACE graphical screens.

3.4. CONTROL PANELS

- A. For any control panel that exceeds 16 inches in any dimension, provide a trough above/below control panel. Trough shall be separated into high and low voltage. Provide a high and low voltage conduit or nipple between trough and control panel. All other conduit that serves the control panel shall enter/exit the trough. Do not terminate any other conduit(s) to the control panel outside of two conduits/nipples identified.
- B. Provide a service loop for all controls wiring. Service loop will be installed in trough above control panel or inside control panel cable tray.

3.5. NETWORK MANAGEMENT FUNCTIONAL REQUIREMENTS

- A. Contractor shall thoroughly and completely configure BAS control devices, software, supplemental software, application programming, network communications, Niagara Framework Control Systems Server (CSS), operator workstations, portable operator's terminal, printer, and network communications to permit the functional requirements of the BAS herein specified. The setup shall include as a minimum the following network management procedures:
 - 1. Automatic backup of the DDC System database to appropriate media.
 - 2. Program, load and debug all software installations, including integration of third-party applications (e.g. analytics and energy management).
 - 3. Network user auditing routine.

3.6. POINT NAMING

- A. Points shall be named consistently. Provide list of point names and point conventions within the submittal phase of the project.
- B. Point naming shall be consistent with an existing standard, such as Project Haystack.

3.7. POWER AND CONTROL WIRING

- A. Contractor shall provide all power source wiring required for operation of all BAS Components provided in this Specification.
- B. Extend 120V power circuits from points provided to control voltage transformers. Where dedicated junction boxes have been provided, coordinate the exact locations with the Electrical Contractor. Where they have not, coordinate the spare circuit breakers to be used with the Electrical Contractor or Owner.

- C. Install electrical components in accordance with NEC, local codes, manufacturer's installation guidelines, and Division 26.
- D. Install all wiring in conduit, except in rated plenum spaces where exposed plenum cable is appropriate. Install all BAS wiring in J-hooks; no wiring will be run with other low-voltage cable (such as Owner IT cable tray). Tie conductors.
- E. Install wire and cable with sufficient slack and flexible connections to allow for vibration of piping and equipment.
- F. Connect manual-reset limit controls independent of manual-control switch positions. Automatic duct heater resets may be connected in interlock circuit of power controllers. Connect hand-off-auto selector switches to override automatic interlock controls when switch is in hand position.
- G. BAS cable for LON will be purple and have "LONMARK" physically written on the cable from the cable manufacturer. BAS cable for BACnet will be orange and will have "BACNET" physically written on the cable from the cable manufacturer. BAS cable for BACnet or other protocols will be blue and have the appropriate protocol written on the cable. All other BAS cable, such as for sensors and other BAS Components, shall be yellow jacket. Surge Protection
 - 1. Contractor shall furnish and install any power supply surge protection, filters, etc. as necessary for proper operation and protection of all Building-Level Controllers, operator interfaces, printers, routers and other hardware and interface devices. All equipment shall be capable of handling voltage variations 10 % above or below measured nominal value, with no effect on hardware, software, communications, and data storage.
- H. All control wiring shall be plenum cable, no riser cable is allowed.
- I. Control wiring conduit shall be blue in color.
- J. Power wiring and conduit shall be consistent with Division 26.

3.8. SENSOR AND DEVICE INSTALLATION

A. General Installation

- 1. Install aspirating guards on wall-mounted devices in the following locations:
 - a. Building entrances.
 - b. Public areas.
 - c. Where indicated on construction documents.
- 2. Exposed wire nuts, including in plenum, will not be acceptable. All connections will be made inside a rated enclosure.
- 3. Install labels and nameplates to identify control components according to Section 23.
- 4. Install hydronic instrument wells, valves, and other accessories according to Section 23.
- 5. Install refrigerant instrument wells, valves, and other accessories according to Section 23.
- 6. Install duct volume-control dampers according to Sections 23.
- 7. Smoke detectors, high and low limit thermostats, high-pressure cut-offs, and other safety switches shall be hard-wired to de-energize equipment as described in the sequence of operation. Switches shall require manual reset. Provide contacts that allow DDC software to monitor safety switch status.

8. Coordinate fire alarm relay connections to the fire alarm system with the fire alarm installer.

B. Temperature/Humidity/Wall Module and Room Sensors Installation

1. Verify location of thermostats, humidistats, and other exposed control sensors with Drawings and room details before installation. Install devices 48 inches above the floor per ADA requirements. The location(s) to be selected by the Engineer. No sensor shall be mounted until the Engineer/Architect gives specific location instructions. Do not install sensor(s) on the inside of exterior building walls (including column fur outs) unless explicitly approved by Engineer.
2. Air seal wires attached to sensors in their raceways or in the wall to prevent sensor readings from being affected by air transmitted from other areas.
3. Wall Modules
 - a. Limit set point adjustment to plus or minus 3 deg F unless otherwise specified on the Drawings.
 - b. Wall module shall be programmed such that it can be used for TAB support.

C. Current Switches/Transducer Installation

1. Wire may be “wrapped” around CT to obtain better status indication.
2. CTs requiring commissioning/startup will be done per factory installation instructions.

D. Relays

1. Relays will be mounted at a location where pilot light is visible from floor.

E. Electronic Actuators

1. Wire parallel actuators according to manufacturer's recommendations.
2. Check operation of valve/damper-actuator combination to confirm that actuator modulates valve/damper smoothly throughout stroke to both open and closed positions. Check valve for proper closeoff.
3. Damper Actuators
 - a. Install automatic dampers according to Section 23.
 - b. Mount actuators directly on damper shaft or jackshaft unless shown as a linkage installation.
 - c. To compress seals when spring-return actuators are used on normally closed dampers, power actuator to approximately the 5° open position, manually close the damper, and then tighten linkage.
 - d. Provide necessary mounting hardware and linkages for actuator installation.
 - e. Install damper motors on outside of duct in warm areas, not in locations exposed to outdoor temperatures. Provide access door per specifications for any actuator inside of ductwork.

3.9. PRODUCT DELIVERY, STORAGE, HANDLING, PROTECTION, AND CLEANING

- A. All products and materials shall be new, clean, and free of defects, damage and corrosion.
- B. Ship and store products and materials in a manner which will protect them from damage, weather, and entry of debris until final acceptance.

3.10. SITE CLEAN-UP

- A. At conclusion of each day's work, and at the request of the Owner, clean up and remove from the site all rubbish, debris and trash accumulated during the day as a result of work of the Contractor.
- B. Marks on walls or ceiling tiles caused by the Contractor shall be cleaned by the Contractor. Ceiling tiles, drywall, carpet, paint, and all architectural finishes damaged by the Contractor shall be replaced by the Contractor.

3.11. CHECK OUT, START-UP TESTING, ADJUSTING, AND CALIBRATION

- A. Perform start up, configuration, programming and commissioning coordination on each control product and system to provide fully operable systems.
- B. Contractor shall conduct a point-to-point checkout, which addresses the start-up, testing, adjustments, and calibrations of all work and/or systems under this Specification. Work and/or systems installed under this Specification shall be fully functioning prior to the Functional Performance Testing phase.
- C. System point-to-point check out, verification and documentation are required, and shall be provided for review. Assist the Owner, Engineer, CxA, and/or TAB Firm in verification and Functional Performance Testing (FPT) and Graphical User Interface (GUI) acceptance testing.

3.12. GRAPHICAL INTERFACE

- A. Graphical User Interface (GUI) Development. The Contractor shall develop the graphics, tools, features, and network integration as required.

3.13. FUNCTIONAL PERFORMANCE TESTING (FPT) PROCEDURE

- A. Provide submittals as specified and receive approval.
- B. Install BAS. Obtain Owner acceptance of each phase of installation when installation consists of a renovation in an occupied space.
- C. Maintain redlines of shop drawings throughout install process, for use during FPT.
- D. Provide the Owner an agenda and schedule of CCO testing activities for approval and coordination.
- E. Provide written notice that the system is ready for Owner acceptance testing. Schedule BAS Demonstrations and Owner.
- F. Demonstrate BAS systems to Owner. Perform FPT including sequence of operation, point to point verification to graphical interface, historical data logging, and alarms.
- G. Owner to provide detailed punch list to contractor.
- H. Contractor to repair issues on Owner punch list in seven (7) calendar days.
- I. Contractor provides all usernames, passwords, software, GUI, databases, licenses, and application programming tool(s) to the Owner.
- J. Contractor Trains Owner on all aspects of the BAS including architecture, devices, software, final sequences and modes of operation.
- K. Owner issues letter to contractor declaring that system is substantially complete. Date of this letter starts the warrantee period,
- L. Revise and submit as-built record Drawings and O&M Manuals.
- M. Final Acceptance. Owner issues letter to contractor accepting system.

3.14. CLOSE-OUT DOCUMENTATION

- A. Close-out Documentation (Operating & Maintenance Documentation and Manuals)

will be provided to the owner upon project completion.

- B. Provide all documentation as required in the submittal process, updated to as-built conditions.
- C. In addition, provide the following:
 1. Include control response, settings, set points, throttling ranges, gains, reset schedules, adjustable parameters and limits.
 2. A table (or similar) of all Testing, Adjusting and Balancing (TAB) values for each piece of MEP Equipment and BAS-calibrated equipment, such as airflow metering stations (AFMS).
 3. Any O&Ms for equipment not originally included in the submittal, in addition to product data.
 4. Accurately record actual set points, calibrations/offsets, and settings of controls, final sequence of operation, including changes to programs made after submission and approval of Shop Drawings and including changes to programs made during specified testing.
 5. Database of all point names and/or Niagara template file for use during expansion of project.
 6. Software backup of entire BAS and associated components on digital media for Owner record.

PART 4 - FIGURES

4.1. DEVICE, BUILDING AND NETWORK-LEVEL CONTROLLERS AND/OR SERVERS

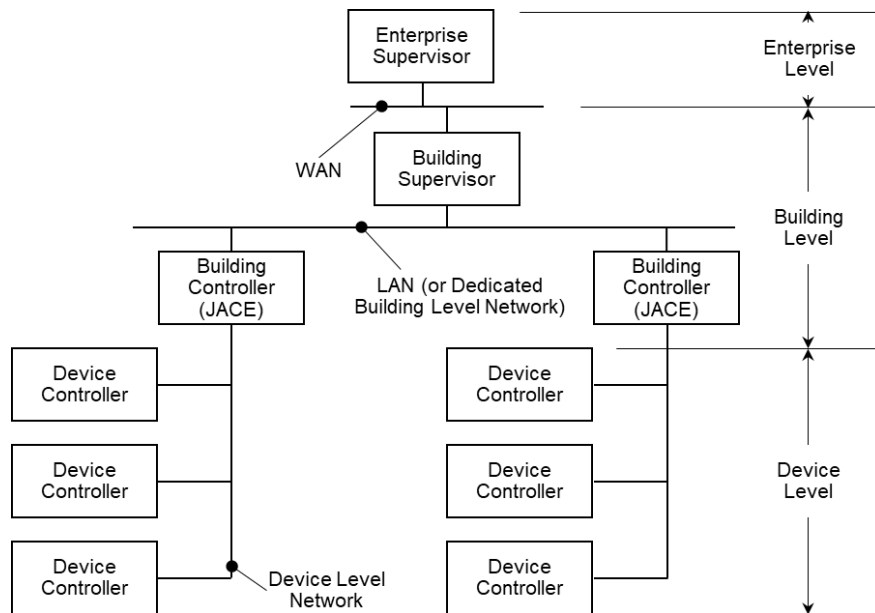

Attachment C



Town of Morrisville



The Value of Building Automation Systems (BAS) In Town Buildings

Superintendent

Chris Lennon
Facilities & Fleet

1.0 Introduction

1.1 Overview

Building Automation System (BAS), also referred to as Building Management System and Building Control System, is an architecture that describes a means of controlling many building operations such as the HVAC (Heating, Ventilation and Air Conditioning), lighting, security and other key systems required for day-to-day operations all from a single, remote location.

It is considered a distributed control system that integrates access to multiple building systems all from a central point. Furthermore, the power of the architecture really stands out when you extend control over multiple building systems for multiple buildings, all from one remote location.

1.2 Purpose

Providing central control over one or more buildings has many possible advantages. The goal is to reduce costs in multiple areas which include utilities, labor and problem resolution time. Being able to see problems before they are noticed by the customer is a huge advantage in being proactive and providing superior customer service.

2.0 BAS Implementation

BAS is a vertical architecture that is added to an operations plan on top of existing systems. Controls using this architecture replace manual controls such as thermostats, light switches and on-site monitoring of equipment such as backup generators and exterior safety lighting. Many of these projects focus on the control of HVAC systems because those are the systems that utilize more energy than all the other electrical appliances and fixtures in a building. So, the focus of this document is on HVAC systems and their control by BAS.

As BAS is implemented on top of a building's HVAC system, manual thermostats are replaced with networking thermostats connected to the customer's VPN by either CAT6 cabling or Wi-Fi. Temperature sensors are installed in the return ductwork to sense and report ambient temperatures and installed in supply ducts to sense output air temperature.

There are at least three major areas that BAS brings value to. Each is identified and described in detail.

2.1 Utility Cost Reduction

Even though manual thermostats can be programmed to switch into Unoccupied mode at certain times, say after 6:00pm on Monday through Friday, many systems will be programmed to remain in Occupied mode so that late night meetings will remain in comfort. As a result, it is easier and safer to leave out the Unoccupied mode where heating and cooling is reduced.

With a BAS system attached to the HVAC systems, any change of plans for a building can be easily adjusted from a single location including the home of the Facilities Supervisor. Eliminating these exposures because of remote controls makes these switching of modes much more attractive because of the reduction of the risks mentioned above. The results are the savings in utilities.

The following illustration shows the first three full months of electric bills for one of the suites before BAS (2021) and after BAS (2022):

<u>Year</u>	<u>January</u>	<u>February</u>	<u>March</u>
2021	21704	23394	20264
2022	19603	21276	14155
Delta	9.7%	9.1%	30.1%

Note that the first two months were utilized tuning the system and adjusting the timing to get the biggest payback in utility savings without jeopardizing the comfort of the employees.

2.2 Maintenance Reduction

Before BAS, once a work order came in for a comfort problem (i.e., an HVAC problem), we would receive the work order, dispatch a Facilities Tech to the location, investigate the legitimacy of the problem and then decide what to do. With BAS, we are not only aware of the problem before it is reported, but we can also diagnose the problem in many cases with error codes provided by the BAS system which mean the HVAC company under contract can be called sooner and arrive earlier. The savings here are in vehicle fuel and labor hours. A conservative guess on the labor hours per incident covered by a BAS implementation is .5 - .75 hours.

2.3 Improve Customer Service

As indicated above, being able to notice a problem before it is reported and then being able to decide if a Facilities Tech can handle it or if it requires a professional HVAC Tech reduces the time to resolution. Being able to save the estimated .5 - .75 hours as specified above makes a difference in the number of work orders we can process in a day. The quicker we resolve a problem and the more problems we can resolve in a day, raises our level of customer service.

3.0 Future of BAS

Because of the success we have had with the BAS pilot program at the Public Safety buildings, the remaining Town facilities have been assessed for a BAS implementation. Criteria such as cost, problems, alarms, complaint etc. is being used to assess the order in which BAS will be installed. The following list is the order at which BAS will be proposed to be installed in the next five Town buildings:

- 1.) Town Hall – This building will often house meetings to the public such as the council meetings that take place every other Tuesday. In addition, the building size is smaller and is alarmed. I researched connecting BAS to the alarm system because when alarmed, no one is in the building which would be a signal for BAS to put the building in unoccupied mode.
- 2.) Morrisville Aquatic & Fitness Center – This building has primarily residents (i.e., members) in the building. The facility is opened for long hours and utilities are very high. BAS has an opportunity to make a significant difference.
- 3.) Connector Building – this building only has two HVAC units so it will be an easy install. Furthermore, it has an alarm system which will give us the largest savings possible by

putting system in “Unoccupied” as soon as the last person leaves the building for the night.

- 4.) Senior Center – This facility is unoccupied for about 75 % of the time. It has an alarm system which BAS can be tied into. It has three HVAC units which makes it an easy install.
- 5.) Historic Christian Church – this building has only two HVAC units which makes it an inexpensive install, an alarm unit and currently it is unoccupied about 90% of the time even though the thermostat will be at an “Occupied” temperature setting with an empty building. This facility will have one of the highest percent of energy reductions.

4.0 Conclusion

BAS allows a single person to control systems operating in multiple buildings. Reducing costs and labor is key to the success of Public Works operations. As the Town continues to add building square footage that needs support, the Facilities group may go years before additional personnel is approved. In the meantime, we must discover and use technologies that will allow us to survive. BAS is one of those technologies that will make a difference.

The initial investment to implement the technology is costly but it is a one-time charge that immediately starts to pay off in reducing utility costs, controlling support labor, and reducing the mean time of problem resolution.

Attachment D

Tree Planting Detail

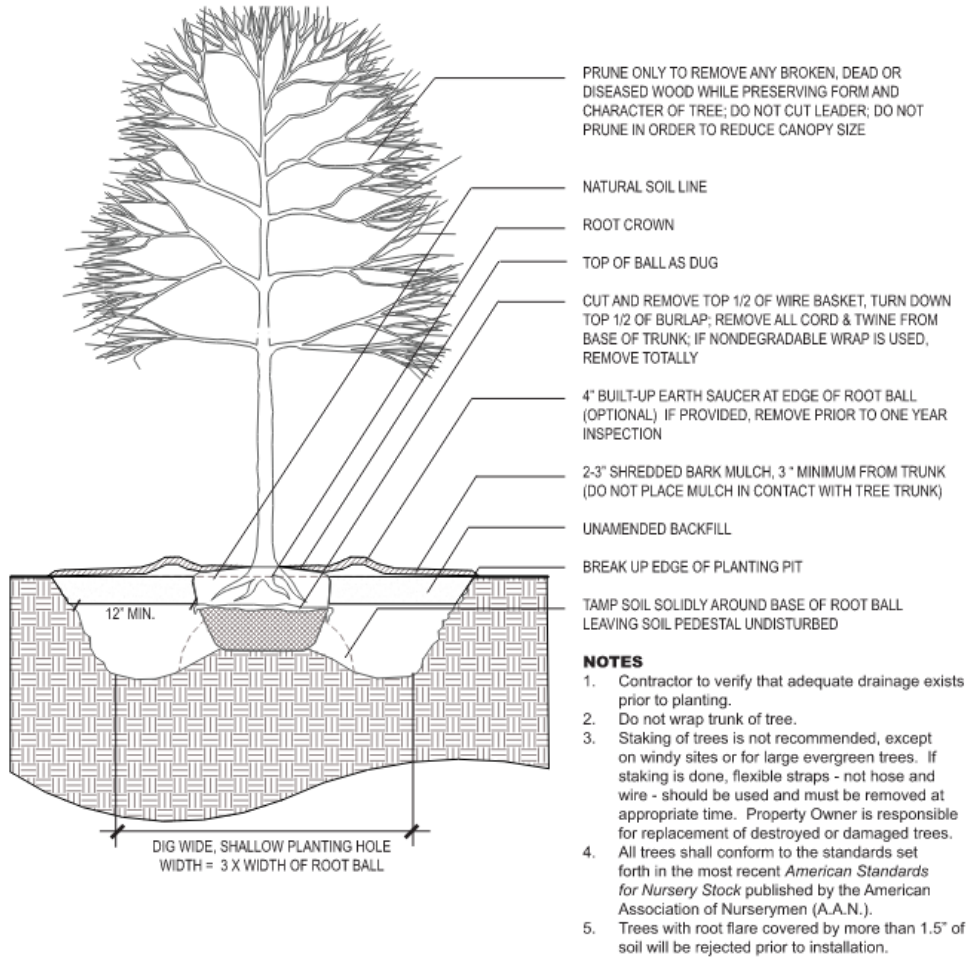

Shrub Planting Detail

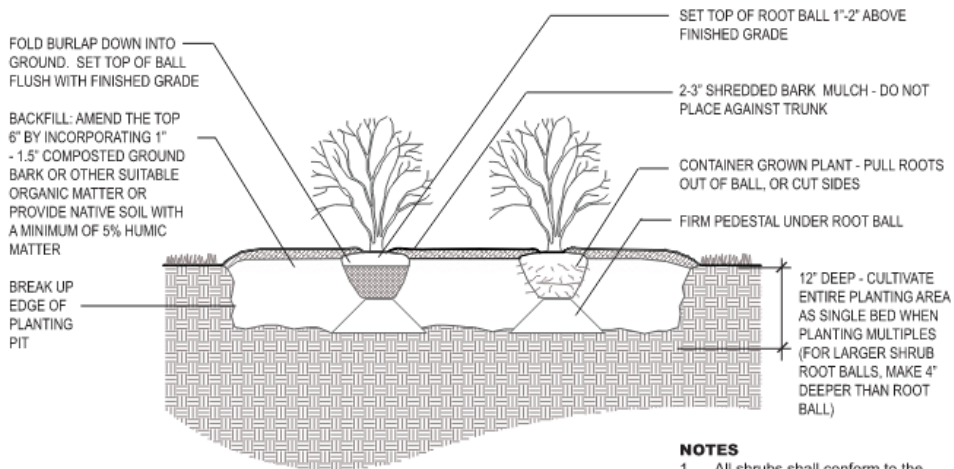

NOTES

1. All shrubs shall conform to the standards set forth in the most recent *American Standards for Nursery Stock* published by the American Association of Nurserymen (A.A.N.).
2. Soil analysis shall be obtained prior to planting. Soil shall be amended as recommended.
3. Sheet preparation of beds is highly preferred to individually dug holes.

Attachment E

Single Trash/Recycle Receptacle



THOMAS STEELE DIVISION
 GRABER MANUFACTURING, INC.
 1080 UNIEK DRIVE
 WAUNAKEE, WI 53597
 P(800) 448-7931, P(608) 849-1080, F(608) 849-1081
 WWW.MADRAX.COM, E-MAIL: SALES@MADRAX.COM

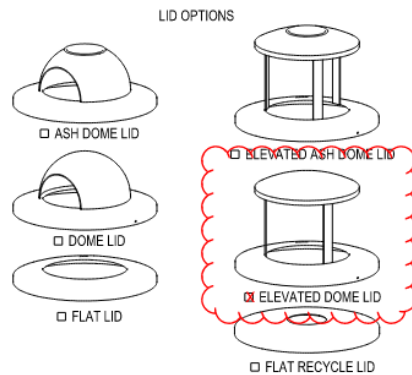
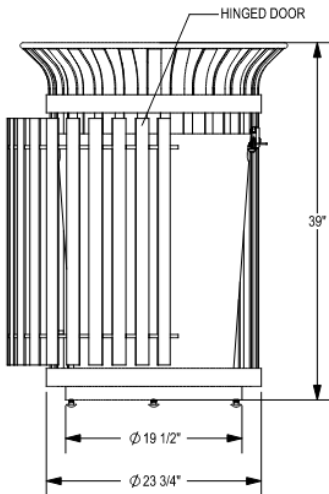
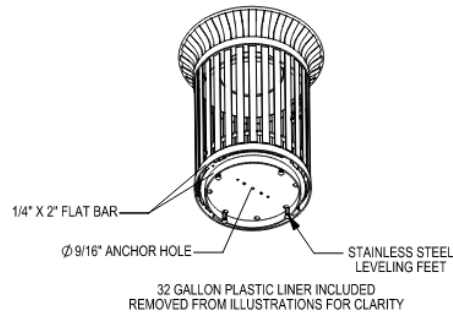
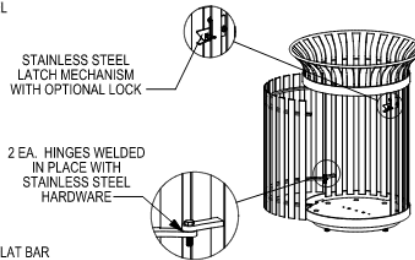
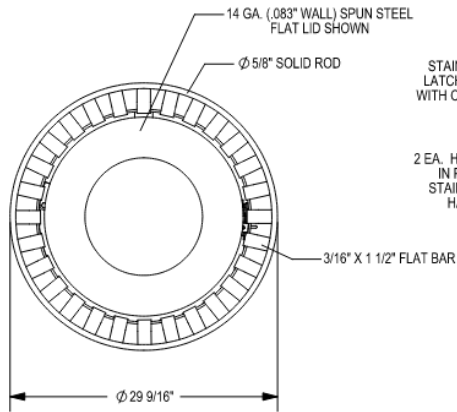

PRODUCT: CRTR-32-DOOR
 DESCRIPTION: CARNIVAL TRASH RECEPTACLE 32 GALLON, WITH DOOR

DATE: 5-21-20
 ENG: SMC

CONFIDENTIAL DRAWING AND INFORMATION IS NOT TO BE COPIED OR DISCLOSED TO OTHERS WITHOUT THE CONSENT OF GRABER MANUFACTURING, INC. SPECIFICATIONS ARE SUBJECT TO CHANGE WITHOUT NOTICE.

©2020 GRABER MANUFACTURING, INC. ALL PROPRIETARY RIGHTS RESERVED.

TRASH LIDS ARE ATTACHED WITH 2 EA. STEEL VINYL COATED AIRCRAFT CABLE. PLASTIC LINER INCLUDED. ALL FASTENERS ARE STAINLESS STEEL.

SITE FURNISHING IS POWDER COATED WITH TGIC POLYESTER. STEEL SURFACE PREP INCLUDES MECHANICAL AND CHEMICAL ETCHING FOLLOWED WITH A COATING TO IMPROVE ADHESION AND CORROSION RESISTANCE.

Dual Trash Receptacle



THOMAS STEELE DIVISION
 GRABER MANUFACTURING, INC.
 1080 UNIEK DRIVE
 WAUNAKEE, WI 53597
 P(800) 448-7931, P(608) 849-1080, F(608) 849-1081
 WWW.MADRAX.COM, E-MAIL: SALES@MADRAX.COM

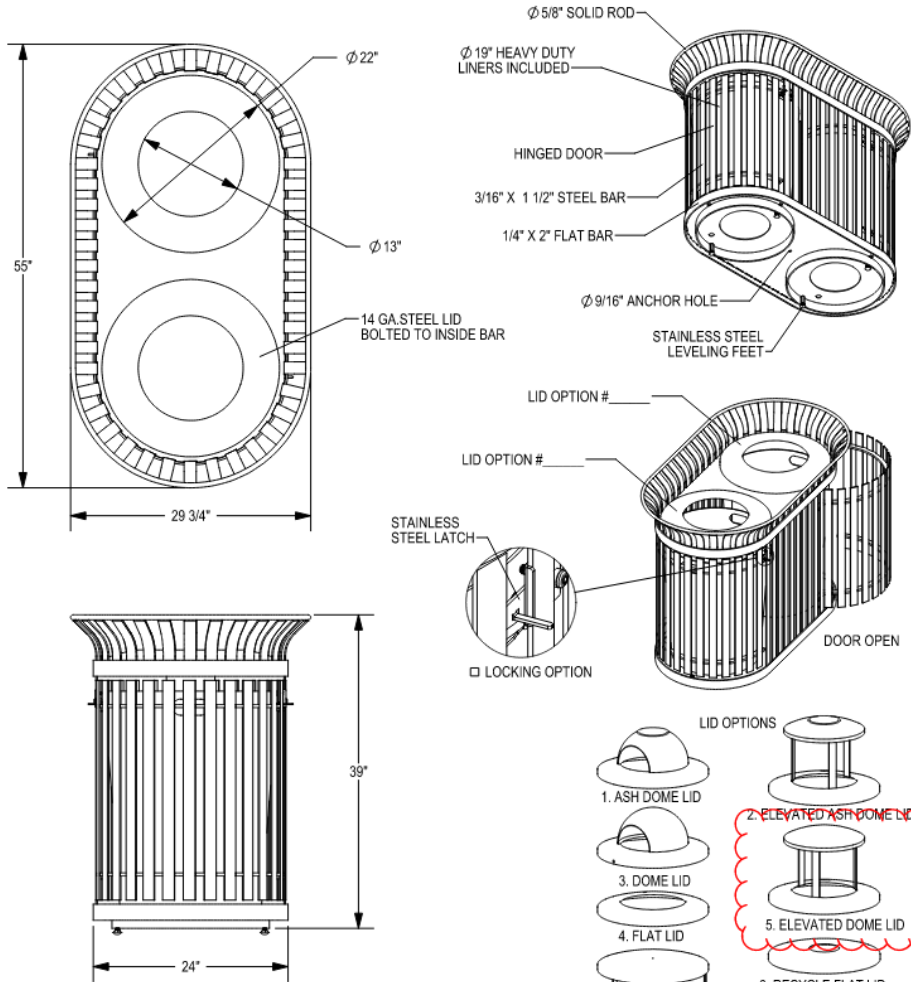

PRODUCT: CRTR2-32-DOORS
 DESCRIPTION: CARNIVAL DUAL TRASH RECEPTACLE, WITH DOORS

DATE: 2-22-19
 ENG: SMC

CONFIDENTIAL DRAWING AND INFORMATION IS NOT TO BE COPIED OR DISCLOSED TO OTHERS WITHOUT THE CONSENT OF GRABER MANUFACTURING, INC. SPECIFICATIONS ARE SUBJECT TO CHANGE WITHOUT NOTICE.

©2019 GRABER MANUFACTURING, INC. ALL PROPRIETARY RIGHTS RESERVED.

LID OPTIONS

1. ASH DOME LID
2. ELEVATED ASH DOME LID
3. DOME LID
4. FLAT LID
5. ELEVATED DOME LID
6. RECYCLE FLAT LID
7. LARGE ELEVATED LID

ALL FASTENERS ARE STAINLESS STEEL

SITE FURNISHING IS POWDER COATED WITH TGIC POLYESTER. STEEL SURFACE PREP INCLUDES MECHANICAL AND CHEMICAL ETCHING FOLLOWED WITH A COATING TO IMPROVE ADHESION AND CORROSION RESISTANCE.

Bicycle Rack



Approved by Town of Morrisville Engineering Dept
4/29/2021

MADRAX DIVISION
GRABER MANUFACTURING, INC.
1080 UNIEK DRIVE
WAUNAKEE, WI 53597
P(800) 448-7931, P(608) 849-1080, F(608) 849-1081
WWW.MADRAX.COM, E-MAIL: SALES@MADRAX.COM

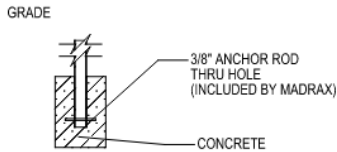
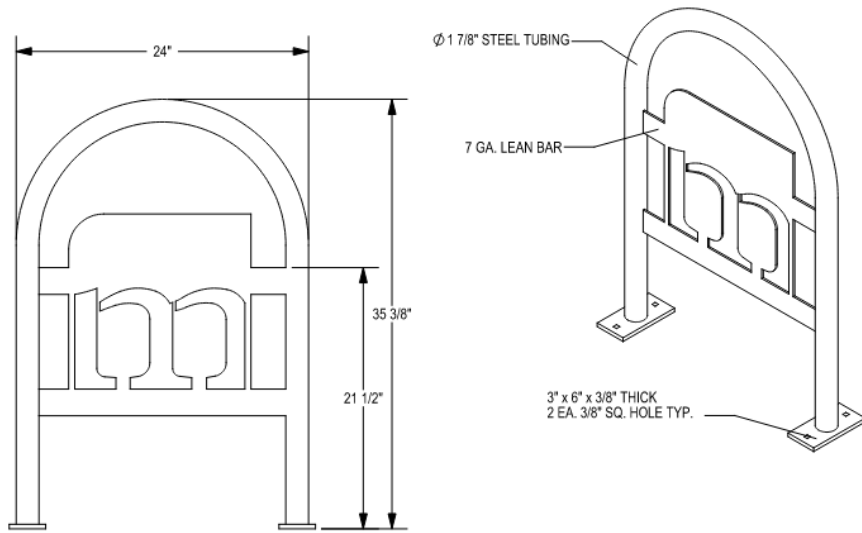

IN GROUND MOUNT (IG)

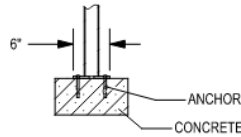

SURFACE FLANGE MOUNT (SF)

SECTION VIEWS

CHECK DESIRED MOUNT

PRODUCT: U24-MORRISONVILLE
DESCRIPTION: 'U' BIKE RACK WITH CUSTOM MORRISONVILLE LEAN BAR
2 BIKE, SURFACE OR IN GROUND MOUNT, BRONZE COLOR
DATE: 2-8-18
ENG: SMC

CONFIDENTIAL DRAWING AND INFORMATION IS NOT TO BE COPIED OR DISCLOSED TO OTHERS WITHOUT THE CONSENT OF GRABER MANUFACTURING, INC. SPECIFICATIONS ARE SUBJECT TO CHANGE WITHOUT NOTICE.

©2019 GRABER MANUFACTURING, INC. ALL PROPRIETARY RIGHTS RESERVED.

- NOTES:
1. INSTALL BIKE RACKS ACCORDING TO MANUFACTURER'S SPECIFICATIONS.
2. CONSULTANT TO SELECT COLOR (FINISH). SEE MANUFACTURER'S SPECIFICATIONS.
3. SEE SITE PLAN FOR LOCATION OR CONSULT OWNER.

Bench



APPROVED Town of Morrisville Engineering Dept
4/29/2021

THOMAS STEELE DIVISION
GRABER MANUFACTURING, INC.
1080 UNIEK DRIVE
WALUNAKEE, WI 53597
P(800) 448-7931, P(608) 849-1080, F(608) 849-1081
WWW.MADRAX.COM, E-MAIL: SALES@MADRAX.COM

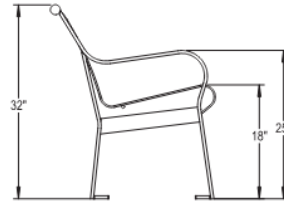
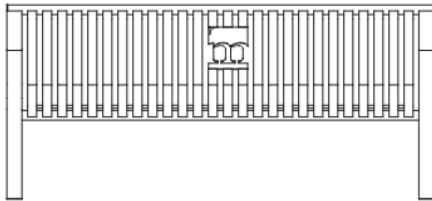
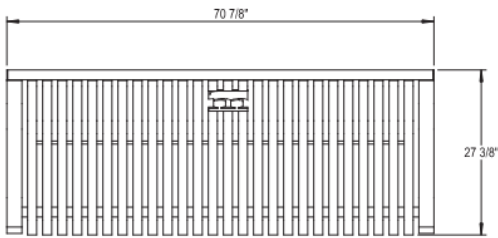
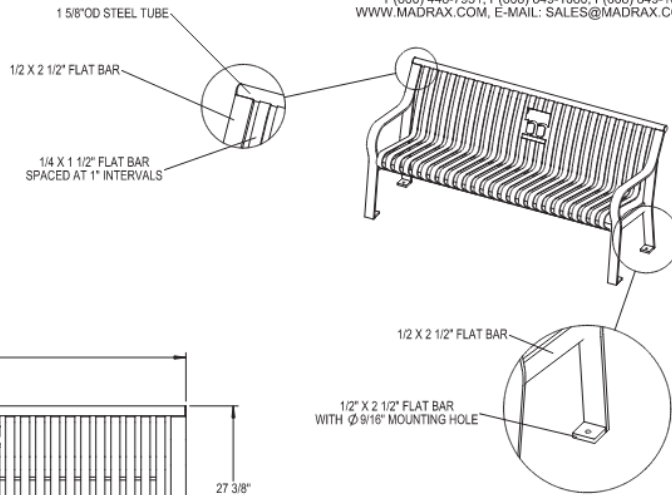

PRODUCT: CRB-MORRISVILLE
DESCRIPTION: CARNIVAL BENCH WITH MORRISVILLE INSERT
BRONZE COLOR
DATE: 6-1-18
ENG: SMC

CONFIDENTIAL DRAWING AND INFORMATION IS NOT TO BE COPIED OR DISCLOSED TO OTHERS WITHOUT THE CONSENT OF GRABER MANUFACTURING, INC. SPECIFICATIONS ARE SUBJECT TO CHANGE WITHOUT NOTICE.

©2018 GRABER MANUFACTURING, INC. ALL PROPRIETARY RIGHTS RESERVED.

SITE FURNISHING IS POWDER COATED WITH TGIC POLYESTER. STEEL SURFACE PREP INCLUDES MECHANICAL AND CHEMICAL ETCHING FOLLOWED WITH A COATING TO IMPROVE ADHESION AND CORROSION RESISTANCE.